

Guidelines for improving building safety and resilience for new single storey houses and schools in rural areas of Fiji

2019



MINISTRY OF  
INDUSTRY, TRADE  
AND TOURISM

---

Level 2 and 3, Civic Tower,  
Victoria Parade  
Suva, Fiji



# Acknowledgements

The Guidelines were developed under the leadership of Ministry of Industry, Trade and Tourism (MITT) with technical and financial support from the World Bank and its consultants, Alexander & Lloyd Group.

Extensive inputs were provided by stakeholders within the government of Fiji including: Ministry of Economy, Ministry of Health and Medical Services, Ministry of iTaukei Affairs, Ministry of Education, Heritage and Arts, Ministry of Housing and Community Development, Ministry of Infrastructure and Transport, Natural Disaster Management Office, Ministry of Local Government, Ministry of Women, Children and Poverty Alleviation, Ministry of Lands and Mineral Resources, Suva City Council. Other stakeholders that contributed and/or consulted include Fiji Technical College, Habitat for Humanity, Fiji National University, and the Construction Industry Council.

Additional financial support for drafting of the Guidelines was also provided by the European Union (EU) in the framework of the ACP-EU Natural Disaster Risk Reduction Program, managed by the Global Facility for Disaster Reduction and Recovery (GFDRR) within in the World Bank.

The Guidelines draw on the work of development partners after Tropical Cyclone (TC) Winston in March 2016 and lessons learned from the 150 or so school buildings in rural areas that have been rebuilt after TC Winston.



**GFDRR**  
Global Facility for Disaster Reduction and Recovery

**ACP-EU Natural Disaster Risk Reduction Program**  
*An initiative of the African, Caribbean and Pacific Group, funded by the European Union and managed by GFDRR*

# Foreword



It is with great pleasure that I present the *Guidelines for improving Building Safety and Resilience of New Single Storey Houses and Schools in Rural Areas of Fiji*. The National Building Code for Fiji (NBC) was completed in 1990 and enacted in 2004 through the Public Health (National Building Code) Regulations 2004. Associated with the NBC, a *Home Building Manual* was developed which details the requirements of the NBC. Both the NBC and the *Home Building Manual* are targeted at building professional including engineers, architects and by necessity are technical and complex. The technical nature of the documents makes it hard for Inon-technical practitioners and home owners to get access to good practices for construction of single storey houses, especially those in rural areas and in iTaukei lands. Compliance to the NBC can add to the cost of construction and can also extend the time for construction. Fiji government when enacting the NBC, thus agreed that houses in iTaukei lands would be exempted from the NBC. This means that if good practices in design and constructions are not followed, these buildings may be at greater risk of damage during cyclones and earthquakes.

During Tropical Cyclone Winston in 2016, about 30,000 houses and 495 schools were damaged or destroyed, mostly in rural areas. The major cause of the damage was due to buildings not adhering to

the NBC requirements and/or not being maintained. Given the extent of the damage, there is a clear need for having simple guidelines and good practices that can improve the quality and resilience of new single storey houses which are the norm in iTaukei lands. The first part of these Guidelines with graphics and emphasis on good practices, will help improve the quality of the houses on iTaukei lands. Now that all public school buildings require a building permit, the second part of the Guidelines will help community leaders and construction firms ensure that our schools are safe, resilient against cyclones and meet the requirements of the NBC.

I am keen to establish a certification of building practitioners to contribute to improving the resilience and safety of the single storey homes in iTaukei lands and schools in rural areas. Such certification needs to be underpinned by training. I am pleased that the material in the Guidelines will be adapted for such training, allowing us to move ahead with certification.

I encourage home owners, construction firms, builders, carpenters, households, village councils, and government agencies to use these Guidelines. Their pictorial nature makes them easy to improve quality of houses and adopt good practices in construction.

A handwritten signature in black ink, appearing to be 'Premila Kumar'.

**HON. PREMILA KUMAR**  
**MINISTER FOR INDUSTRY, TRADE AND TOURISM**

# Contents

Overview of the Guidelines.....	6
<b>PART A: Guidelines for New Single Storey Houses in iTaukei Lands.....</b>	<b>7</b>
1. Introduction.....	8
2. Before Construction Starts.....	8
2.1. Selecting a site.....	8
2.2. Getting everything together.....	9
3. Design and Construction System for a Safer House.....	10
3.1 Cyclone connections.....	10
4. Foundations & Footings.....	12
5. Floor Construction.....	14
5.1. Timber floors.....	14
5.2. Concrete floors.....	14
6. Wall Construction.....	15
6.1. Timber wall framing.....	15
6.2. Concrete masonry walls.....	16
7. Bracing.....	17
8. Roof framing.....	18
8.1. Roof shape.....	18
8.2. Roof sheeting.....	19
9. Good Practice in Construction, Repair & Maintenance.....	20
9.1. Star rating.....	20
9.2. Simple maintenance regime for single storey-houses.....	20
9.3. Star Rating Checklists.....	21
<b>PART B: Guidelines for Resilient New School in Rural Areas of Fiji.....</b>	<b>24</b>
1. Introduction.....	25
2. Resilient School Construction.....	25
2.1. Where do you start?.....	25
2.2. Minimum Infrastructure Standards.....	25
3. Before Construction Starts.....	28
4. Foundations, Footings & Floor Construction.....	28
4.1. Concrete Floors.....	28
4.2. Cyclone connections.....	30
5. Wall Construction.....	30
5.1. Concrete masonry walls.....	30
6. Roof Framing.....	31
6.1. Bracing.....	31
6.2. Roof Sheeting.....	31
7. Simple Maintenance and Repair Regime.....	32
8. Good Practice in Building Applications & Inspections.....	33
8.1. Acquiring a Building Permit.....	33
8.2. Building Inspections.....	34

# Overview of the Guidelines

*Guidelines for Improving Building Safety and Resilience of New Single Storey Houses and Schools in Rural Areas* have been developed to improve the resiliency of single storey houses and schools against cyclonic winds and earthquakes. They draw on good practices developed after Tropical Cyclone (TC) Winston in rebuilding houses and schools.

The National Building Code for Fiji (NBC) and Home Building Manual were completed in 1991, and enacted in 2004 through the Public Health (National Building Code) Regulations 2004. Given the cultural and governance issues within iTaukei lands, the houses and community schools in these areas were exempted from the requirements of the NBC. However, the need for the predominantly single storey houses to be resilient to cyclonic winds and earthquakes in these areas is paramount, especially with the increasing impacts of climate change. **Part A** of the Guidelines is targeted at people building a house (home owners, carpenters, individual builders) in iTaukei lands. Given this target audience, Part A is pictorial to help the material be accessible to a range of practitioners who help home owners build houses in iTaukei lands. The contents take the target audience through the decisions on the physical location of the building, especially in landscapes with steep slopes to the completion of the roof. The contents include good practices in deciding the physical location of the building, especially in landscapes with steep slopes that can reduce the risk to houses and schools.

**Part B** of the Guidelines is aimed at village level institutions responsible for management and construction of schools. As with the Part A, the material in Part B is pictorial in nature to ensure its use and accessibility by the target audience. It draws on the standards used by the Ministry of Education, Heritage and Arts. Again, the Guidelines provide good practices for each stage of construction of a school. For new community schools in iTaukei lands, once

the site is selected, the land as of 2019 is treated as leasehold. This means the school buildings need to comply with the NBC and the community needs to obtain a building permit before construction starts. The recent changes to the institutional arrangement for the enforcement of the NBC means that the application for the building permits must be made to the municipal councils. All municipal councils have their own processes; the Part B of the Guidelines include the process used by the Suva City Council to help the target audience apply for a permit and include a checklist of the requirements for building permit application. The checklist can also assist the municipal council staff and inspectors during the review of the building permit application and in determining compliance during site inspections at critical stages of construction.

Both Part A and B highlight the need to understand the risks to a **building from natural disasters**. This includes selection of a site before construction starts, with encouragement to select as flat a site as possible as this reduces the overall risk to the building. The National Disaster Management Office of Fiji ([www.ndmo.gov.fj](http://www.ndmo.gov.fj)) provides guidance to help understand and plan for natural disasters.

**Regular maintenance** of any building after construction contributes to their resiliency in the event of an earthquake and/or cyclones. Both Part A and B thus include a simple maintenance checklist that can be used by home owners and/village institutions to help in maintenance of houses or schools, particularly prior to the cyclone season.

The Guidelines are developed to form contents of the training for vocational training institutions, national and provincial government staff from key agencies and building professional operating mainly in rural areas and iTaukei lands and thus will contribute to certification of builders in the future.

PART A:  
Guidelines for New Single  
Storey Houses in iTaukei Lands

# 1. Introduction

This section takes you through the different stages of a construction, from selecting a site, foundations & footings to the roof sheeting.

It emphasises the need for regular maintenance and provides a checklist which can be used to provide a star rating for a single storey house if the village chooses to.

Whilst most construction in Fiji is controlled by the NBC, houses in iTaukei lands were exempted from the NBC. This means the construction of houses

in iTaukei lands does not require a building permit. However, such construction and site selection is controlled by the village governance processes and linked to the iTaukei Affairs Board. In general, the Mataqali is responsible for approving construction. The iTaukei Affairs Act (Cap 120), Amendment to the Decree 2012 (Decree No. 22 of 2012) also legislates the establishment of iTaukei Affairs Board with powers that allow it to submit recommendations and proposals to the Minister that related to the well-being of the iTaukei people.

## 2. Before Construction Starts

Before you get underway with building, you need to have a careful look at the site and think about some of the things that could go wrong that could slow down the construction process, make it more expensive, or result in your house not lasting as long as it should. There are a few questions that you need to ask yourself to help overcome these issues, such as:

- Is your site flat and level?
- Is the site too close to a river or the ocean, where flooding can happen?

- Can you access it easily while you are building your home?
- Can any trees fall onto your new house and damage it or hurt you or your family?

### 2.1 Selecting a site

Selecting the flattest site for the house within a landscape can itself reduce the risk of damage and destruction to a house.

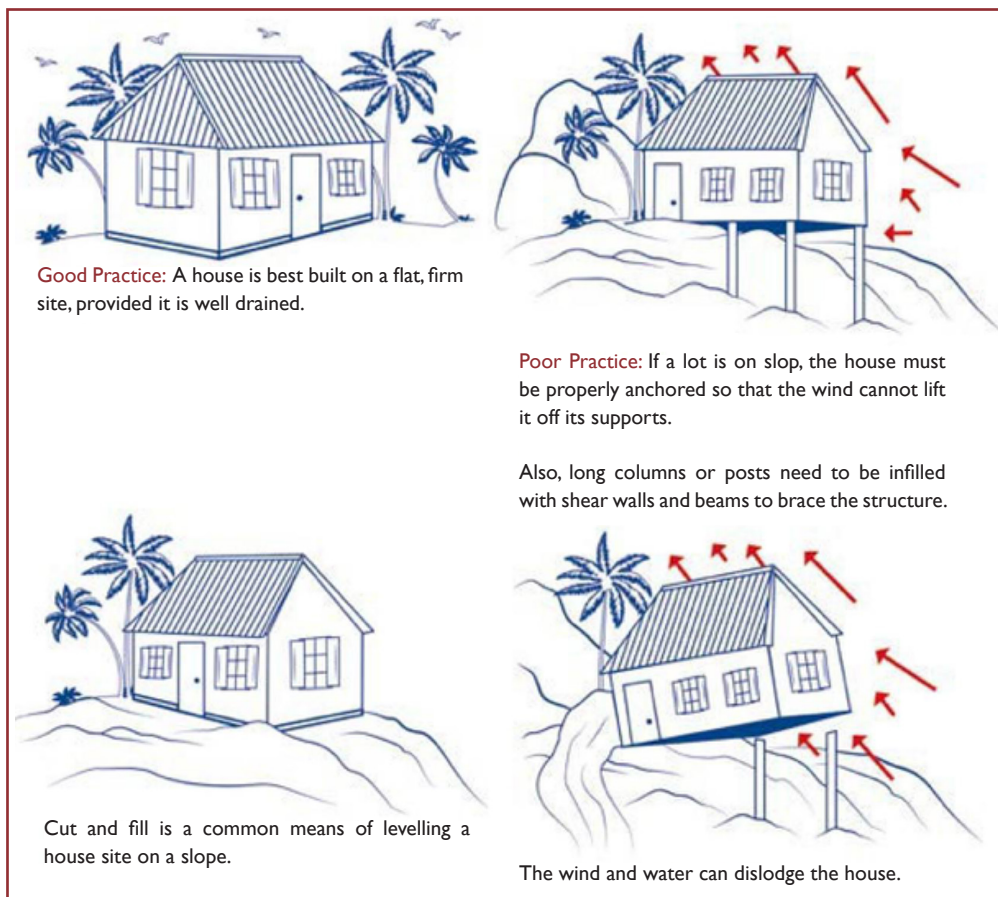

Figure A1: Site selection for a home



## 2.2 Getting everything together

Before you start, you need to make sure you have everything you need. This includes any permissions, any drawings or other documentation describing what you are building, as well as the materials and tools to build it. But if you are not sure, there are many resources available to help, from the National Building Code for Fiji and the Home Building Manual, to other government departments and NGO's, who are helping Fijians to Build Back Better after the serious cyclones in recent years.

It is important that you don't make any changes to the designs that you have, as there may be unintended

consequences: making a window larger, for instance, may make the structure weaker. Likewise, making changes after construction has finished, like adding an open verandah attached to the side of a home a few years after the first construction was completed, needs to be carefully considered so it does affect the house itself. If you do want to make a change, or undertake an addition, seek advice first.

There many resources available to help, including from government departments (like the Ministry of Housing and Local Development) and Civil Society Organisation (CSOs), who are helping with Building Back Better after the series of cyclones in recent years, especially TC Winston.



Figure A2: Fiji Shelter Handbook: Inclusive and Accessible Shelter Planning for Fijian Communities (Source: Shelter Cluster Fiji)

THESE TIPS WILL MAKE YOUR HOUSE STRONGER

## Tips to Build Back Safer



Shelter Cluster Fiji  
ShelterCluster.org  
Coordinating Humanitarian Shelter

BUILD SAFER  
BUILD WISER. THIS WILL SAVE YOU MONEY. MAKE SURE YOU DON'T MISS ANYTHING OUT ...HAPPY BUILDING!

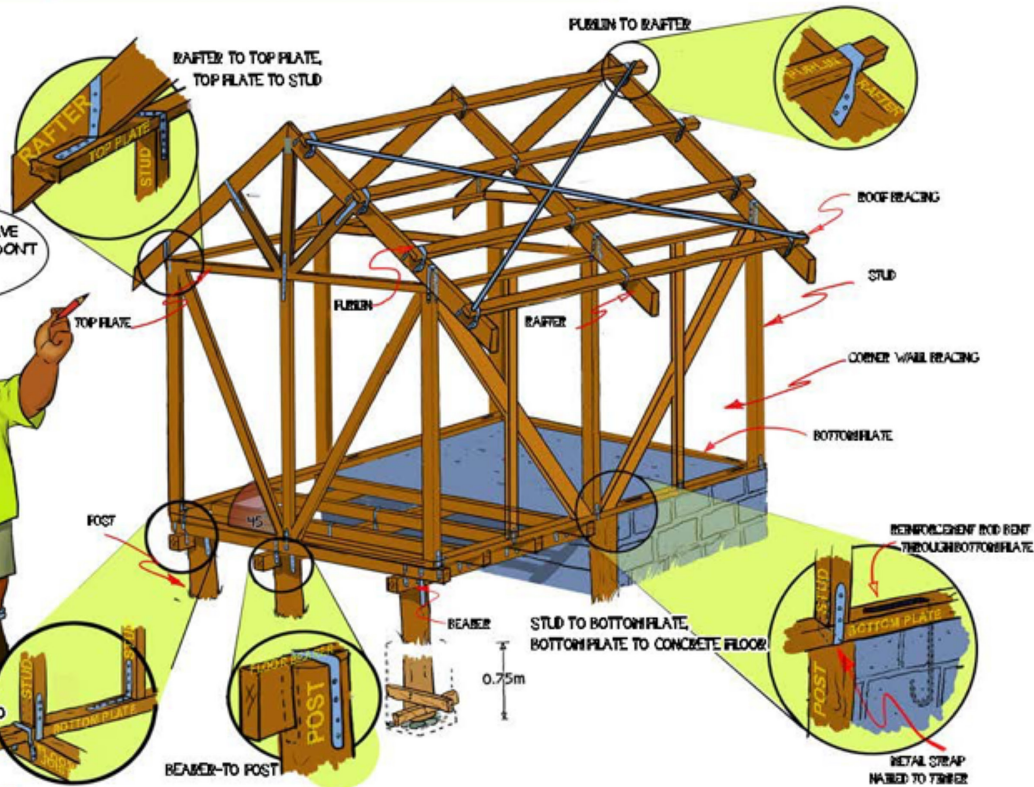

Supported by ENTEC LIMITED

refer to the Home Builders Manual [www.mit.gov.fj](http://www.mit.gov.fj) for more information

Figure A3: Tips to Build Safer poster distributed after TC Winston (Source: Shelter Cluster Fiji)

## 3. Design and Construction System for a Safer House

There are several methods available to make a building resistant to a risk, such as a cyclone or an earthquake. The design for your house includes one of these methods, such as bracing, or reinforced blockwork. Do not change the construction method after you start construction. Making changes to a building after completion, but without the right consideration, could compromise the safety of a building, such as adding a deep veranda roof with a light frame that is connected to the main roof of a building.

### 3.1 Cyclone connections

All of the systems in a house need to be properly connected to ensure they can resist the forces from the wind of a cyclone, which can push and pull with great strength in quick succession. It is important that all of the cyclone connections are used, to minimise the risk of a weak link that can fail and cause significant damage to a structure.

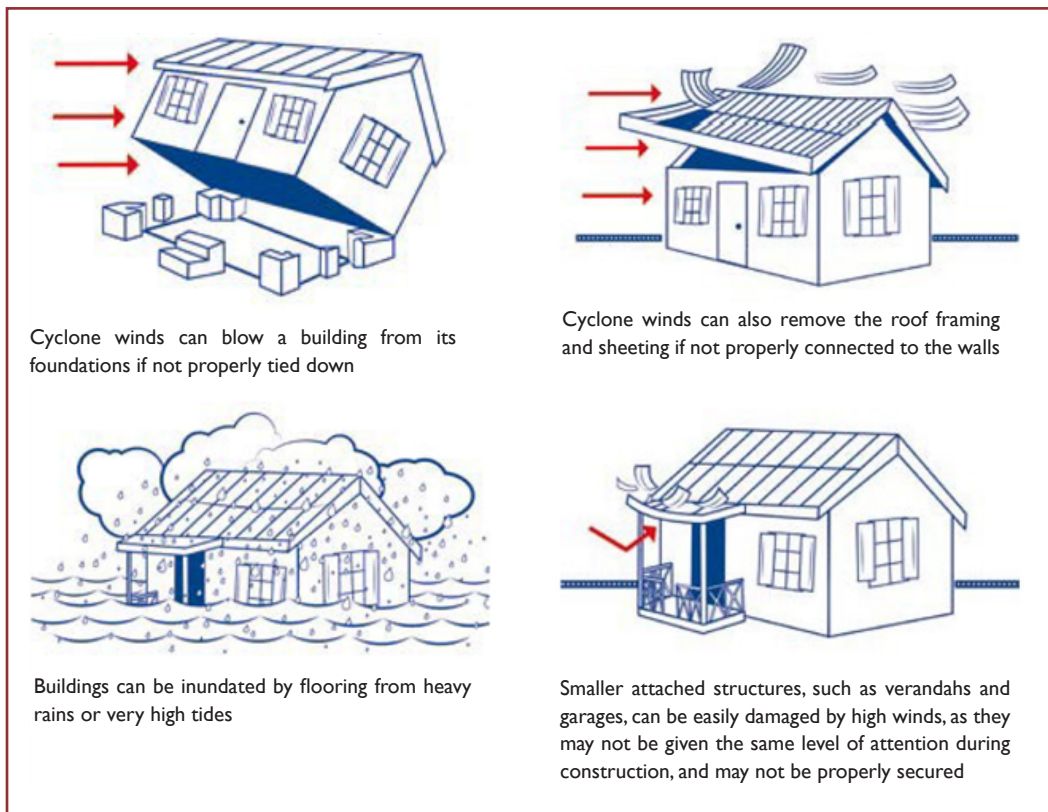

Figure A4: Impact of cyclones on buildings

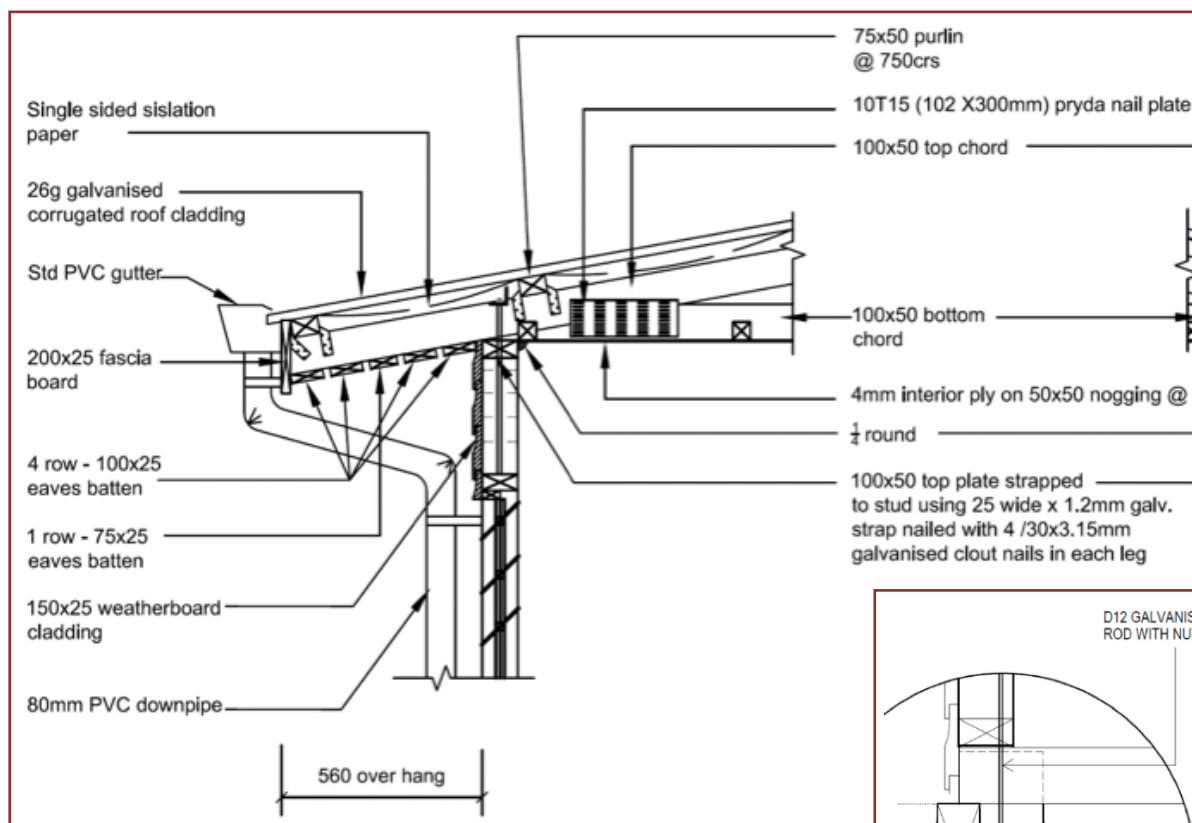

Figure A5: Cyclone rod connection at roof framing (Source: Fiji Rural Housing Unit standard drawings)

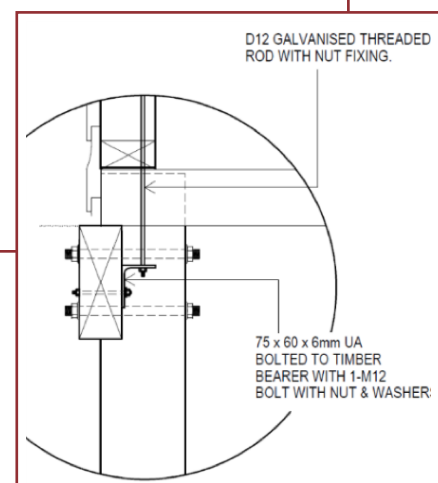

Figure A6: Cyclone rod connection at floor bearer (Source: Fiji Rural Housing Unit standard drawings)





Figure A8: Aggregate & sand measuring box

For the same reason, it is very important to use potable water in the concrete mix, and to only use enough water to make the mix usable. If the mix is too wet, the concrete will not become strong enough. Again, do not use salt water.

If possible, mix the concrete as close as possible to where you are going to be placing it. This is especially

important if you are mixing the concrete by hand, or on hot or windy days.

Place the concrete as soon as possible after it has been mixed, and tamp it into place, to get out air bubbles. On hot and sunny, or windy days, the concrete can lose moisture and dry out very quickly before it starts to set, potentially making the concrete weaker than it needs to be. Do not use concrete that has started to set.

Support embedded posts or any reinforcement while concrete is being placed. Wrap the base of the post in Visqueen (builder's black plastic sheeting), for the full depth of embedment, to protect the timber from the concrete. Make sure the plastic is well taped. It's OK for the steel rebars to punch through the sheet, although try to avoid too many holes. When placing the concrete, be careful of placing the concrete around the steel bars in the posts, the plastic around the post, and any other reinforcement.

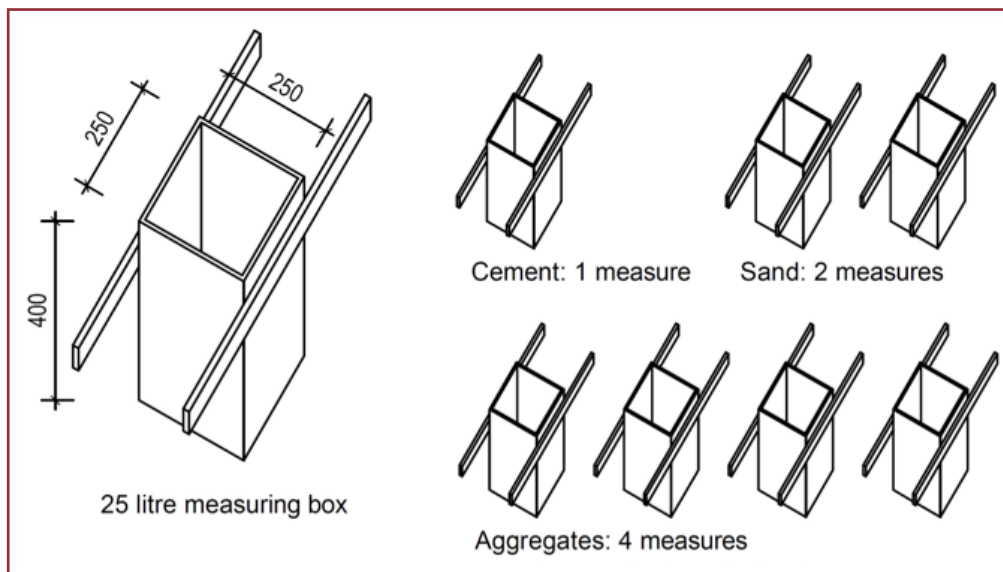

Figure A9: Typical concrete ingredient measuring box and proportions

Use the correct reinforcement in footings. Connect lengths of reinforcement by lapping (the minimum lap for D12 bar is 500mm; for D16 use 650mm). Do

not join reinforcement by welding. Make sure there is at least 50mm from the edge of the footings to any reinforcement, including any ties or hoops.

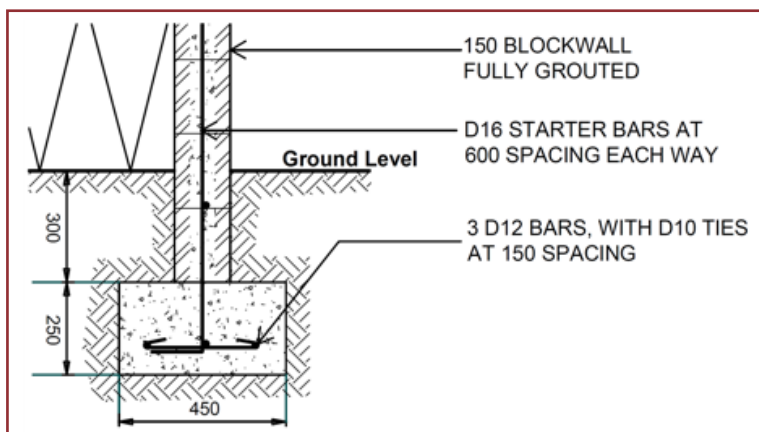

Figure A10: Reinforced concrete footing (Source: Fiji Rural Housing Unit standard drawings)

# 5. Floor Construction

Your house, like many others, will have a timber floor. If you are planning to have a concrete floor, please go to section 5.2.

## 5.1 Timber floors

Timber floors need to be raised up about ground level to ensure the timber does not rot. Usually, there need to be at least 600mm from ground level to the underside of the first horizontal member is good. And timber in contact concrete needs to be painted with a bituminous paint, and be either a resilient hardwood, or treated softwood for the same reason. These timbers should also be resistant to termites, either naturally, or by chemical treatment.

Different timber species have different strength and durability grades, which can affect how much of a material will be required (such as size of members required for a task, or the spacing between members), or how long the timber should be expected to last, which is known as its service life. All timbers (posts, floor, framing, wall framing, roof framing) should have a strength grade of at least F7. The durability of timbers can vary significantly, however availability of some grades may be limited. Timbers directly exposed to the weather, but in well ventilated positions, such as weatherboards, should have a durability of at least H3. This should be increased to H5 if placed in the ground, such as a post placed into a footing.

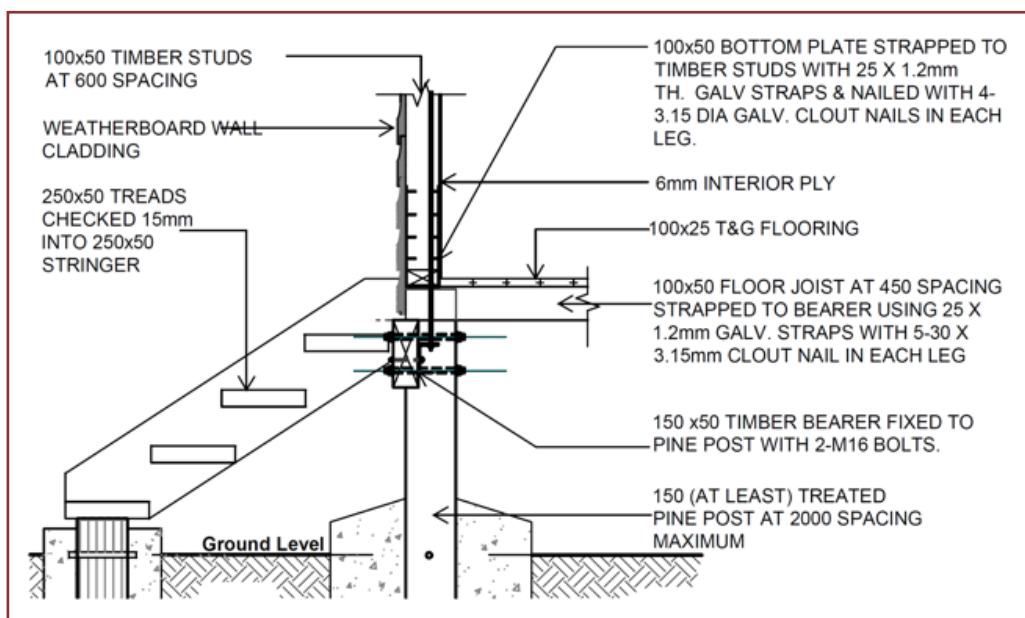

Figure A11: Timber floor system at entry threshold (Source: Fiji Rural Housing Unit standard drawings)

## 5.2 Concrete floors

Often, concrete floors can be quite expensive, because of the amount of the components required (cement, sand, aggregates) and the cost of their transport to site. More care is needed when they are set up, as you will need to be able to place a lot to concrete quickly, and, once the concrete has set, it is very hard to make changes.

Remove the top 100mm of top soil from the ground that the concrete floor will cover. Place hardcore fill up to the level that you need and compact it well. It is best to place the fill in layers of up to 150mm at a time and compact it as you go: you can't properly compact a thick layer of fill. You may need to dig part of the fill out for thickenings and different floor levels.

Place a 50mm layer of sand on the top of the fill and

compact this layer as well.

Dig out areas of the hardcore where you need to place any drains and set the pipes with the right fall on soft sand. Hold the pipes in place while you relay the fill over the pipes.

Place sheets of Visqueen (builder's black plastic sheeting) on top, to make sure moisture from the ground doesn't come through the concrete. Tape all of the joints of the plastic so that it is fully sealed, and tape the sheet to any penetrations, such as drain pipes.

Set the steel reinforcement mesh in place, at a level so that there is enough concrete covering the steel. This cover is usually at least 25mm.

If the concrete needs to have falls in it, so that you can drain a wet area, be ready to set those levels when the concrete is being placed. Make sure the minimum thickness of concrete and cover to the reinforcement is maintained.

Make sure any reinforcement or bars that extend out of the slab are in place before the concrete sets.

When the concrete is in place, or while it is being placed, and before it has set too much, the surface can be screeded to the desired levels, and any surface treatments applied, such as trowelling.

After the surface has been finalised and set, the surface should be covered with a wet cloth like hessian, and kept wet for several days, to minimise any surface cracks.

## 6. Wall Construction

### 6.1 Timber wall framing

Timber wall frames are built up from studs of a common size, usually 100x50mm. The main members are the top plate, bottom plate, and studs, and are

usually made from the same sized timber. There are intermediate noggins to provide additional strength. The noggins can also be used to support attachments to the wall, such as cupboards or taps.

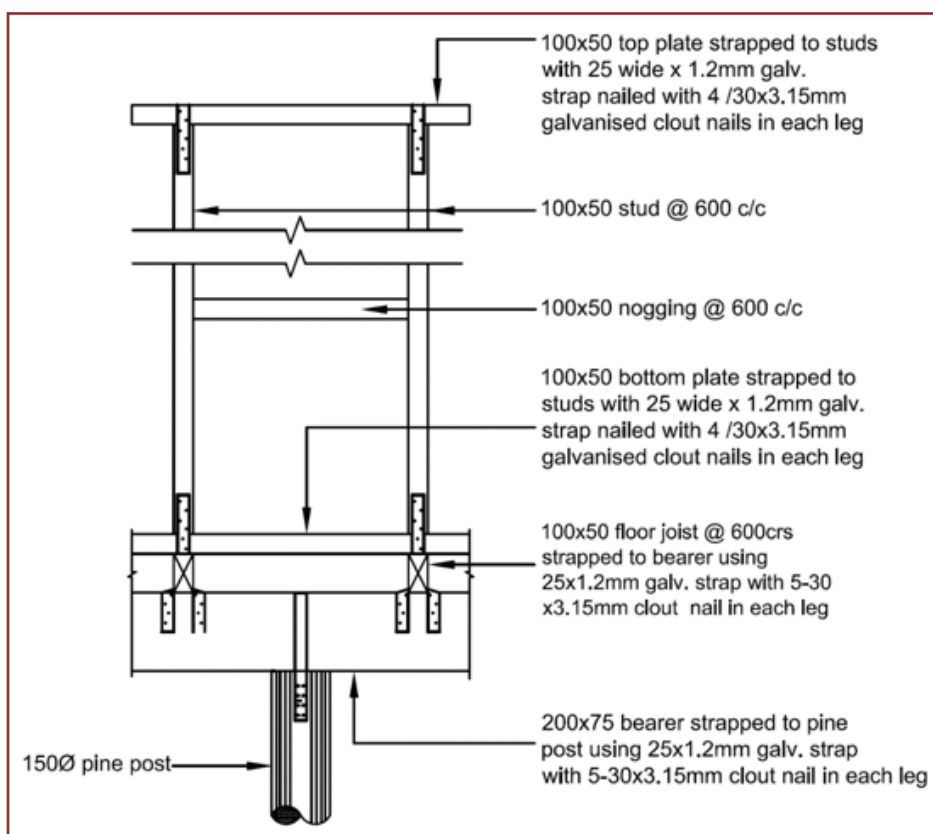

Figure A13: Strapping overview for timber stud wall (Source: Fiji Rural Housing Unit standard drawings)

Additional galvanised steel strapping at each stud over the top and bottom plates create a stronger wall frame better able to withstand cyclonic winds. The strapping must be properly secured to the timber frames.

In walls that are load bearing, a lintel or beam may be needed an opening is made in the wall, such as a door or a window. Additional studs may also be needed on the sides of the opening to provide support to the lintel.



Figure A14: Stud wall frame with galvanised steel cyclone strapping (Source: Fiji Rural Housing Unit)

## 6.2 Concrete masonry walls

Walls can be made from concrete blocks usually when there is a concrete slab for the floor. Because the larger structural masonry blocks used for structural work are hollow in the middle, they need to be backfilled with concrete to ensure they are suitably strong. They also require vertical and horizontal steel reinforcement bars to ensure they are able to resist and transmit loads to the footings. This makes the system quite slow to build, and it can be expensive. However, masonry can be more durable than timber,

in part because of the mass of concrete in the system.

Concrete masonry can be used to support a concrete slab for a wet area, and as a bridge between the footings and timber wall frames.

The top of a reinforced masonry wall will need to have a bond beam round it, to lock the wall together. The bond beam uses masonry units with open ends and continuous reinforcement which is concreted together to create a continuous concrete ring beam.

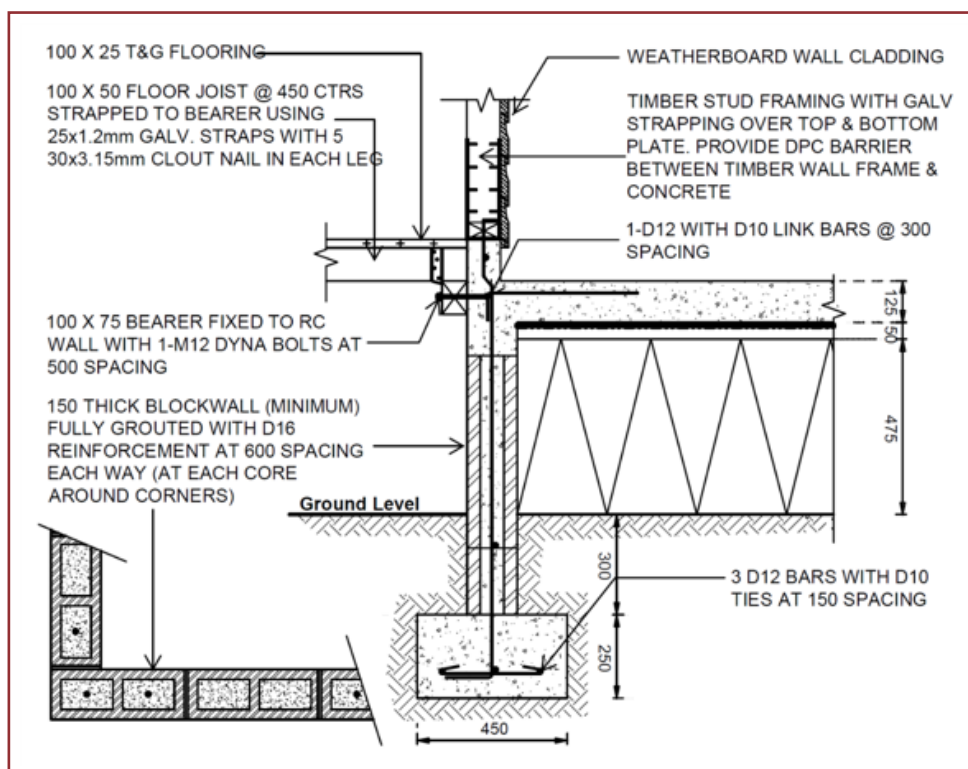

Figure A15: Concrete masonry wall connections (Source: Fiji Rural Housing Unit standard drawings)



# 7. Bracing

Before any linings are added, the large surfaces of the walls and roof need to be braced to reduce the impact of winds and earthquakes. In concrete masonry walls,

the vertical and horizontal reinforcing steel in the walls takes up this role.



Figure A16: Stud frame wall with galvanised steel strap bracing (Source: Fiji Rural Housing Unit)

In timber framed walls and roofs, the bracing is made using galvanised steel strapping that crosses the planes, connecting opposite corners. The bracing needs to be wrapped over the members it is securing and nailed into place. It also must be nailed to the studs. Usually 35mmx3.15 nails are used for this

fixing, with 2 nails are used to secure the brace to every member that the bracing passes over, with an additional 3 or 4 nails used to secure the bracing to the members at the ends, such as a roof chord or rafter, or wall frame top or bottom plate.

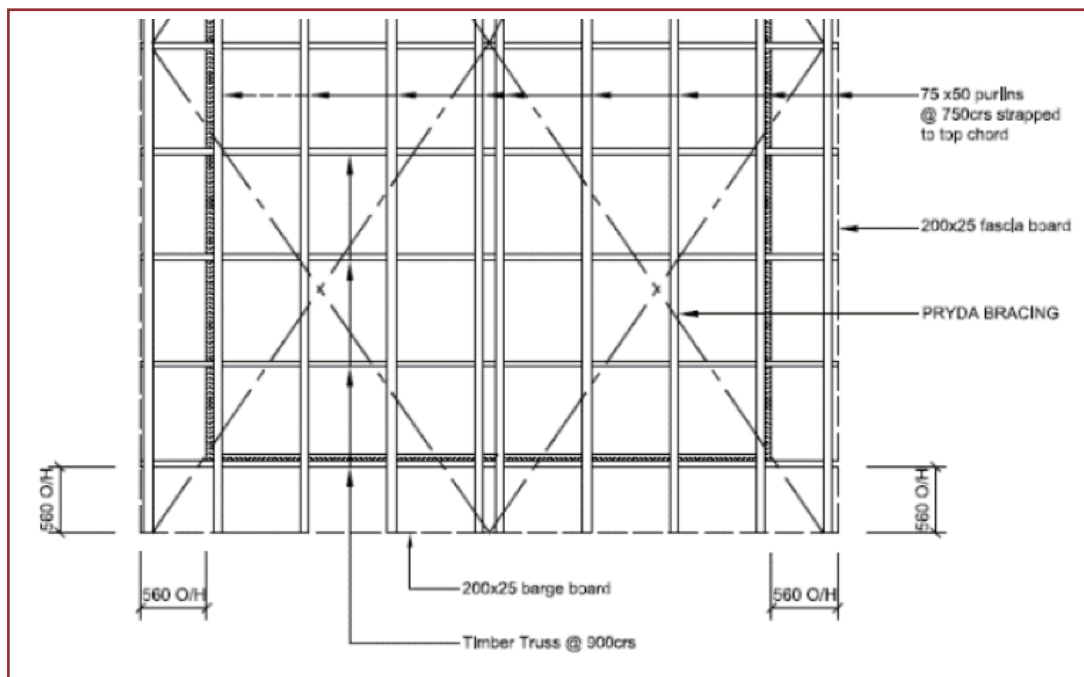

Figure A17: Roof bracing diagram (Source: Fiji Rural Housing Unit)

# 8. Roof framing

There are a number of ways to frame a roof in timber. The sizes of timber required, and their spacing has been worked out to ensure the roof is sufficiently strong. Usually, the rafters are at 900mm spacing, with the purlins (the timber that the roof sheeting is connected to) at 750mm spacing.

## 8.1 Roof shape

Eaves that project out from the wall line are usually kept to about 600mm, and provide a good source of shade to the north and south sides of a house, helping to keep a house cool. If the eaves project too far away from the wall, additional strengthening may be needed to resist cyclonic winds.

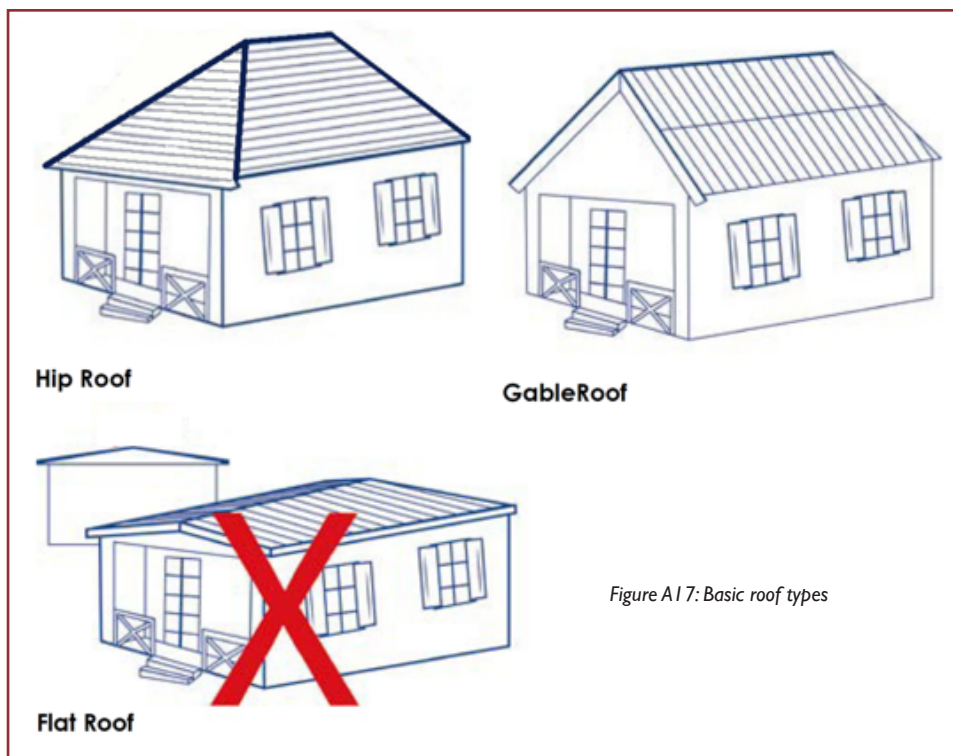

Figure A17: Basic roof types

The pitch of the roof – how steep it is – is an important element in the design. While a shallow pitched roof may be slightly less expensive, from requiring slightly less timber framing, it may well not be able to shed the rain quickly enough when it is raining heavily. Shallow pitched roofs can also be more easily

damaged by strong winds, due to suction. Gabled and hipped roofs also tend to perform better in high wind situations than skillion or low pitched roofs. A rule of thumb for planning is for the height of the ridge from the eaves to be half the width of the gable wall elevation.

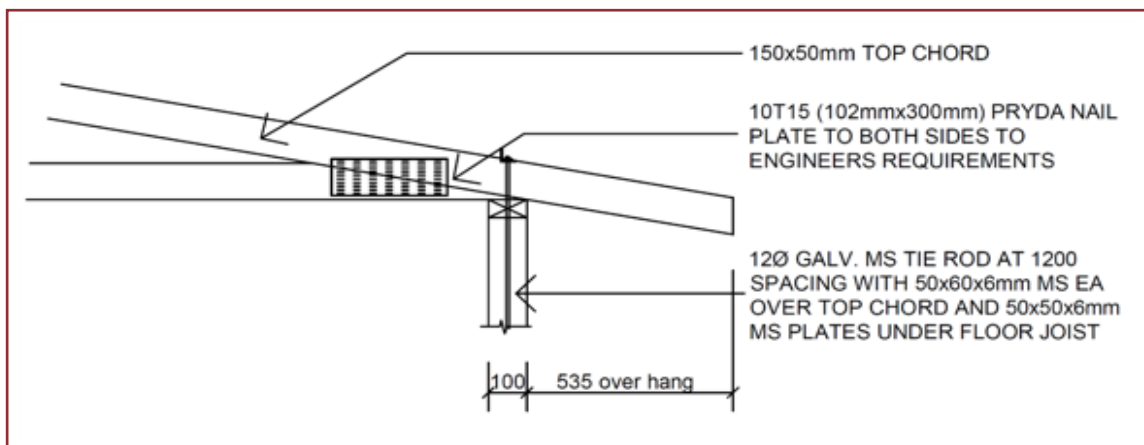

Figure A19: Connection of wall frame to roof frame (Source: Fiji Rural Housing Unit drawings)

The roof frame is connected to the wall frames, and cyclone connections - often galvanised steel strapping, nailed into place - strapping are added to ensure the roof and walls are properly connected to the footings.

Battens or purlins are run on top of the roof framing and are used to connect the roof sheeting to the

roof frame. They require galvanised steel strapping at every connection to ensure the continuity of support. The purlins should be at 1200mm spacing, and this reduces to 600mm spacing over the eaves, and the top (ridge) of the roof, to provide additional support where the wind load can be greatest.

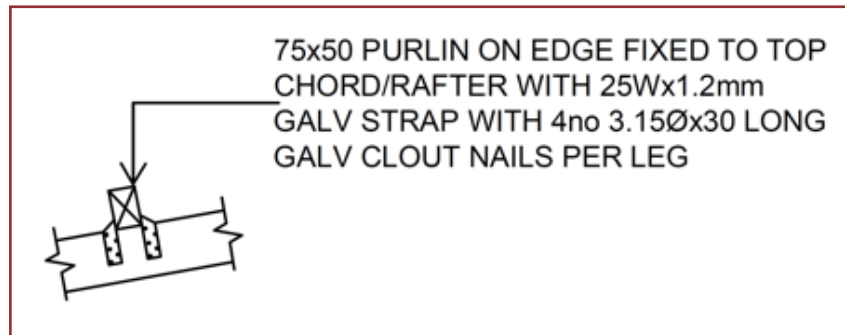

Figure A20: Connection of roof purlin to roof frame (Source: Fiji Rural Housing Unit standard drawings)

## 8.2 Roof sheeting

Carefully planning of the roof installation is required before commencing.

A layer of sisalation, should be placed immediately under the roof sheeting, and over a oayer of chicken wire or safety mesh, to help reduce the heat gain from the large area of roof.

Lay the roof sheeting toward the prevailing weather direction, so that the last sheet laid is the one that the wind tends to blow over first.

The roof sheeting needs to be well connected to the roof framing to ensure it doesn't get lifted off from strong winds. Using roofing screws with cyclone washers to every second crest of the roof sheet will limit the risk of this happening. Additional screws are to be used to every crest at the top connection of the ridge, and at the bottom, at the eaves, as well, where the spacing between the roof battens or purlins reduces due to the extra wind load at the edges of the rood, and therefore require additional support.

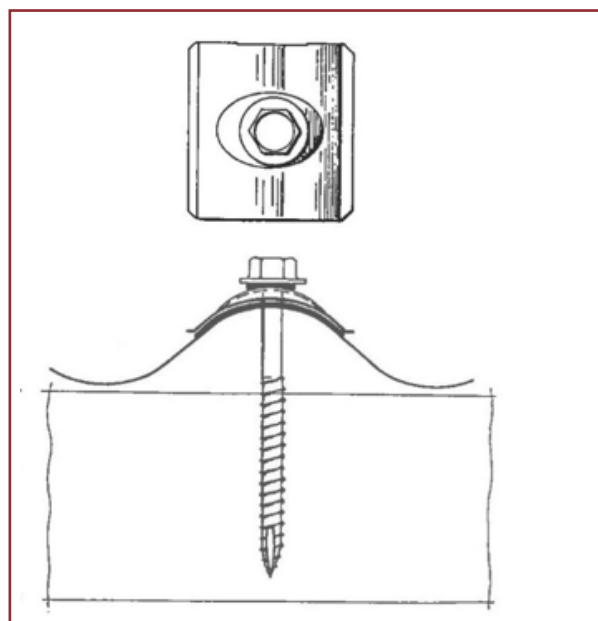

Figure A21: No 14 Type 17 Screw with cyclone washer assembly (Source: Home Building Manual, Fiji)

# 9. Good Practice in Construction, Repair & Maintenance

## 9.1 Star rating

As the houses in the iTaukei lands are exempted from the requirements of the NBC, the Mataqali in the villages could use the “yes/no” answers to provide a star rating for a house. The minimum star rating would be one star and maximum three stars. The proposed star rating is as follows:

One star rating would be awarded if “yes” is achieved for all of the applicable “yes/no” questions relating to Checklist 2: Construction.

Two star rating would be awarded for incorporating the elements of both Checklist 1: Siting and the planning questions in Checklist 2; and

Three stars for all the elements of Checklists 1, 2 and Checklist 3: Repair & Maintenance.

## 9.2 Simple maintenance regime for single storey-houses

Experience and statistics show that the lack of maintenance is a significant contributing factor in damages to houses and schools by cyclones.

Regular maintenance is necessary to ensure that the structure continues to be cyclone resistant. Inspections should be done at least once a year well before the start of cyclone season and after any significant weather events.

You should check the entire house regularly, inside and out, to see if anything needs repairing or replacing and fix it immediately if you can, or make a definite plan to fix it if it is an expensive item.

The most important areas for regular checks are:

- Roof cladding for corrosion and general damage and fixing for missing screws or bolts.
- Roof structure; rafters and purlins for soundness.
- Joints and connections in timber and masonry construction for structural integrity and durability.
- Concrete blocks and slabs for significant cracks.
- Maintain open drainage channels around structures, and ensure the ground falls away from buildings

For timber framed houses, including those elevated on wooden or concrete posts:

- check posts for rot or damage, especially for any damage below ground level.
- check all concrete capping for damage, and that the capping will shed water away from the post.
- check for termites, remove any galleries, and arrange for treatment. Obtain specialist advice promptly if termites are found.

These checklists have been developed with houses in iTaukei lands in mind. Whilst generally applicable to other buildings the use of different construction systems would limit its applicability.

### 9.3 Star Rating Checklists

<b>CHECKLIST 1: SITING &amp; DESIGN</b>		
1.1	<b>PERMISSIONS</b>	
	Has approval from the Mataqali been granted for the house?	Yes/No
1.2	<b>SITING &amp; DESIGN</b>	
	Is the plan a simple plan?	Yes/No
	Is the site flat, or has it been properly cut and filled if it is in a slope?	Yes/No
	In reiverine or coastal areas, has the house been sited away from known flood zones, or other areas of known risk?	
	Has the house been sited away from the toe of a steep slope?	
	Has the orientation of the structure been considered, for sun, & access to the prevailing breeze/wind?	Yes/No
	Is the house at least 2 metres from any neighbouring buildings?	Yes/No
	Does the roof have a significant slope?	Yes/No
	Are the eaves 600mm wide or less?	Yes/No
	Is the house plan the same as its original plan, without any additional lean-tos or verandahs?	Yes/No

<b>CHECKLIST 2: CONSTRUCTION</b>		
2.1	<b>CUT &amp; FILL</b>	
	Will the footings for the building be set in solid ground, and away from any fill?	Yes/No
	If the site is in a cut & fill, is the hill behind the house more than 6 metres from the house?	Yes/No
	Is the cut into the hill less than 3 metre high?	Yes/No
	If “No” to the hill height and distance from the house, is the cut retained at all, such as with gabions, or terraced?	Yes/No
2.2	<b>FOUNDATIONS</b>	
	Are the excavations deep enough?	Yes/No
	Are the footing excavations holes or strips?	Holes/strips
	Are the excavations neat, clean of debris, and dry	Yes/No
	Is there some way of keeping people (especially children) from falling into the excavations?	Yes/No

2.3	CONCRETE	
	Is there enough potable water on site for making concrete?	Yes/No
	Is there sand and aggregate on site for making concrete?	Yes/No
	If the sand or aggregates have been in salt water (such as beach sand), have they been rinsed clean with fresh water?	Yes/No
	Is a consistent volume measure used (such as a large bucket or box) for the consistent measuring of the component quantities for concrete?	Yes/No
	Is there a clear area to mix the concrete without it becoming contaminated?	Yes/No
	Is there enough cover to any steel reinforcement?	Yes/No
	Is the concrete being placed carefully, and tamped or vibrated into place, to prevent the components of the mix segregating before the concrete can set?	Yes/No
2.4	WALLS & FLOORS: TIMBER FRAMED	
	Has timber been sourced from a reputable supplier?	Yes/No
	Has the timber been treated to prevent rot & insect attacks	Yes/No
	Is the durability class of the timber appropriate for the use?	Yes/No
	Have lintels been placed over any openings, such as doors & windows?	Yes/No
	Has a barrier been placed between the timber and any concrete?	Yes/No
	Has the framing been fabricated in accordance with the drawings?	Yes/No
	Has all of the floor frame been connected to the footings with the correct cyclone connections?	Yes/No
	Has all of the wall frame been connected to the floor with the correct cyclone connections?	Yes/No
	Have the wall frames been braced with the correct methods, and with enough connections?	Yes/No
	Has any water treated timber been disposed of without burning? Yes/No	
2.5	WALLS: CONCRETE MASONRY	
	Have the concrete masonry units been bought from a reputable supplier?	Yes/No
	Has the correct reinforcement been placed into the masonry cores, including at the corners?	Yes/No
	Have the horizontal reinforcement been placed around the house, at the correct spacing	Yes/No
	Have all of the cores in the masonry been backfilled with concrete grout?	Yes/No

2.6	<b>ROOF FRAMING</b>	
	Has the all of the roof framing be properly connected to the wall system with cyclone connections?	Yes/No
	Has the roof frame been built with the correct sized members, and with the correct connections?	Yes/No
	Has the roof frame been properly braced?	Yes/No
	Have the roof battens been properly connected to the roof frames with cyclone connections?	Yes/No
2.7	<b>ROOF SHEETING</b>	
	Have roofing screws with cyclone washers been used? Yes/No	
	Have cyclone screws been used to connect the roof sheeting to the roof framing?	Yes/No
	Has the roof sheeting been laid toward the prevailing winds?	Yes/No
	Has the roof been properly cleaned down, to remove any metal pieces from the construction process?	Yes/No

	<b>CHECKLIST 3: REPAIR &amp; MAINTENANCE</b>	
3.1	<b>INSPECTION &amp; MAINTENANCE</b>	
	Has the building been inspected for maintenance at least 1 month before the start of the wet season?	Yes/No
	Roof sheeting: corrosion, missing fixings	Yes/No
	Exterior linings: weather damage or rot	Yes/No
	Exterior structure: damage or rot	Yes/No
	Concrete footings: any damage, like cracking, to concrete capping to footings	Yes/No
	Storm water drainage: open drains are kept clear, and free flowing	Yes/No
	Ground: slope away from building	Yes/No
	Vegetation: trimmed, large trees	Yes/No
	Termites: check for any signs of termite mud galleries	
3.2	<b>REPAIR &amp; PLANNING &amp;</b>	
	Are materials and skills available locally to repair and maintain the building?	Yes/No
	Budget for larger or expensive repairs	Yes/No
	Repaint exterior timber if weathered	Yes/No

PART B:  
Guidelines for Resilient  
New School in Rural Areas of Fiji



# 1. Introduction

This section of the Guidelines is aimed at the village-level institutions (such as Matagali) responsible for management and construction of schools. The material is drawn from the standards used by the Ministry of Education, Heritage and Arts, and adopted and applied for capital projects managed by the Construction Implementation Unit (CIU in the Ministry of Economy. Again, the Guidelines provide good practices for each stage of construction.

After TC Winston, the land for new community schools in iTaukei lands is treated as leasehold in an effort to improve the resilience of school infrastructure. The creation of a lease removes the exemption from formal building approval that is granted to houses in iTaukei lands. All buildings built for school functions must now meet the requirements of the National Building Code for Fiji, and therefore projects must be properly designed and documented, to help ensure the safety of students, and the community in the event of a natural disaster.

It is critical that the conditions on the Building Permit are complied with, including not making any changes to the design without approval, to prevent delays, and

potentially expensive demolition and rework, in order to achieve compliance. Making changes to a building after completion, without the right consideration, can also compromise the safety of a building, such as adding a deep veranda roof with a light frame that is connected to the main roof of a building.

The School Committee/Board must submit an application for the building permit to municipal councils. All municipal councils have their own processes; the Guidelines use the process used by the Suva City Council. A checklist for the typical submission requirement for the building permits is included to help you with the building permit application, however you must seek advice from the Municipal Authority as soon as possible to confirm if other submission requirements are in place.

The checklist is also designed to assist the municipal council staff and inspectors – many of them with requirements that might be new to them - during the review of the building permit application and in determining compliance during site inspections at critical stages of construction.

## 2. Resilient School Construction

Schools are currently being built using either steel-framed or precast concrete panel systems, or using reinforced concrete masonry, to ensure the maximum longevity for a structure. New school buildings are required to be designed to withstand Category 5, severe cyclone events, using an Importance Level of 2. There are standard plans available from the CIU, however these are concept plans only, and require development into construction documentation before work can commence.

There are standard plans available from the CIU in the Ministry of Economy, however these are concept plans only, and require development into construction documentation before work can commence.

The construction documentation of the new buildings must take account of several factors necessary to ensure the buildings are safe to use and provide a safe environment for the students and teachers. In addition to a design wind speed and earthquake risk classification, new school buildings are designed to

Importance Level 4, or Importance Level 4+ if the proposed building has been identified as being an emergency shelter. The Importance Level proscribes an approach to the engineering of the structure that requires professional inputs in the design, and careful monitoring of the construction.

### 2.1 Where do you start?

Once you have confirmed that you want a new building for your school, there are several steps you will need to go through before you start construction. This includes engaging with the Minimum Infrastructure Standards, which are outlined below. You will also need to obtain the necessary permissions.

### 2.2 Minimum Infrastructure Standards

Schools are to refer to the Minimum Infrastructure Standards for Fiji Primary Secondary and ECE Schools 2018 (MIS) by the Ministry of Education, Heritage & Art.

The MIS establish 4 core standards for schools:

- **Standard A: Buildings:** Schools must have appropriate, sufficient and secure buildings
- **Standard B: Health.** Schools must have a healthy, clean secure and learner-protecting environment
- **Standard C: Access.** Schools must have a child-friendly and barrier free environment that promotes inclusive access and equal rights of every child.
- **Standard D: Equipment:** Schools must have adequate and appropriate equipment that supports the quality of education

The Standards require that all buildings be structurally stable, weatherproof for local conditions, climatically comfortable, easily exited in an emergency, and integrated into the local environmental & cultural context.

## Standard A: Buildings

### School layout

The MIS does not proscribe a layout for a school, but does require that the school take into consideration the environmental and cultural situation, indicating that a master planning exercise is required to identify trends and options to make the best use of the available site.

There are many factors to consider in planning a school, including:

- Number of students, including future enrolments
- Type of facility being planned
- Opportunity for expansion with minimising existing uses
- Availability of teachers
- Local environmental features, such as water supplies
- Local cultural expectations

### Classrooms

Classrooms have to be safe, comfortable, accessible, flexible & adaptable & provide sufficient space to ensure children's dignity, health, safety and well-being for successful learning.

Classrooms are to have a minimum of 1.1m<sup>2</sup> of floor space per student, with 20% reserved for the teacher, and a minimum of 6.1m on the shortest side, with at least 0.5m between desks to allow for safe movement. In a primary school, the classrooms must be at least 33m<sup>2</sup> for 30 students, increasing by 0.38m<sup>2</sup> for each additional student. There must be two doors from each classroom for safe evacuation. The Standards describe additional requirements for different types of classrooms and other school

facilities.

## Standard B: Health

### Teacher amenities

Teachers and adults are to have separate facilities for men & women. Sanitary facilities are to be provided on a sex-separated basis of 1 closet for every 20 adults.

### Student amenities

The IS identified that poor sanitation is a major reason for sickness in children, especially girls, and that schools need to make adequate provision for safe amenities. It is also important that light be provided for student toilet blocks if use of the toilets is not restricted overnight.

Student amenities are to be separated by sex, and either within, or close to, the classrooms on a practical and safety basis. For students, 1 closet is required for every 20 girls, for up to 200 girls, and 1 additional closet for every 25 girls from there on; for boys, the ratio is 1 closet for every 33 boys up to 200 boys, and then at a rate of 1 for every 50 from there on. Independent toilet blocks for girls and boys could be considered, if there is adequate available land, allowing for the additional treatment systems and absorption trenches if they are required.

### Amenities for students with disabilities

The IS suggests that amenities for students with disabilities should be provided, with at least one wheelchair-accessible toilet per school, designed with barrier-free access, entry and internal movement. The facilities inside the accessible bathroom must be suitable for the purpose, including handrails, and pan and hand basin heights.

## Standard C: Access

The IS identifies that a school must provide facilities that are reasonable accessible and usable to all, without consideration of age, gender or other special needs. Further to that, the school should encourage the integration of all pupils into the same learning environment.

In planning a new building for a school, a school must allow for reasonable access by all into the learning facilities and related sanitary conveniences. Other considerations include the width of doors & walkways; design of thresholds; and types of floor surfaces.

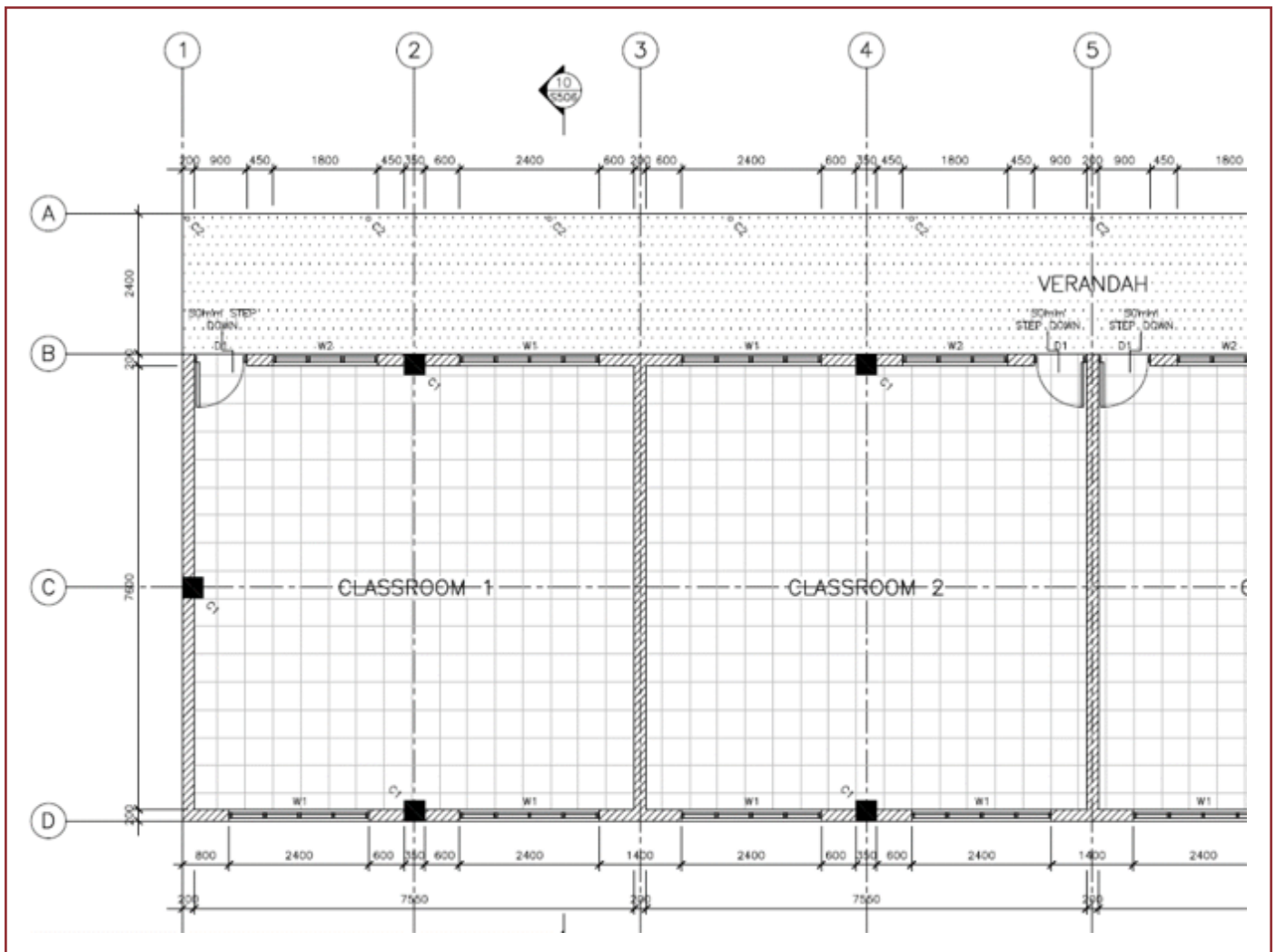

Figure B1: Part floor plan, New Classroom Building, Nailuva District School (Source: Construction Implementation Unit, Ministry of Economy, Fiji)

Ramps with handrails (consider whether one handrail at 800mm high will be suitable, or having two handrails, at 600 high and 900mm high) should be provided where necessary, with landings clear of obstructions, including door swings. Consideration to use comfort must be considered when designing access ramps, as it can be very hard to use a ramp that is too steep.

Also, ramps should be provided in addition to, and not be a replacement for, stairs.

Ramps and stairs should be at least 900mm wide clear between any handrails, and consideration must be given to ensuring the safety of users through reviewing fall risk.

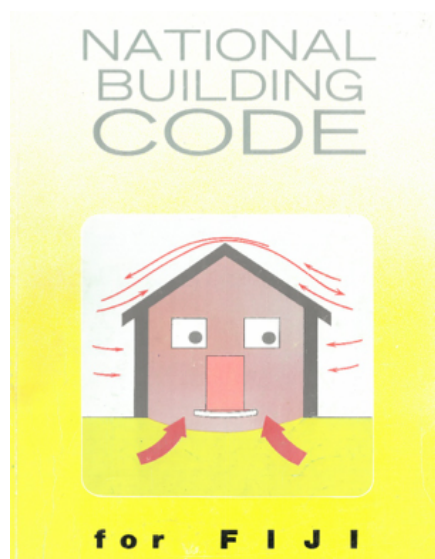

Figure B2: National Building Code for Fiji, and Home Building Manual for Fiji

## 3. Before Construction Starts

Before construction starts, make sure everything that is needed is at hand. This includes any permissions, such as a Building Permit, any drawings or other documentation describing what you are building, as well as the materials and tools to build it.

It is important to avoid making any changes to the documentation that you have, as there may be unintended consequences: making a window larger, for instance, may make the structure weaker. If you do want to make a change, seek advice first, but ideally

these should be resolved during the design phase.

There are several methods available to make a school building resistant to a risk, such as a cyclone or an earthquake. The documentation for your house includes one of these methods. Do not change the method without getting approval. If you make a change, it could void the Engineers Certificate that the building needs to receive government approval for use.

## 4. Foundations, Footings & Floor Construction

The foundations and footings are critical for ensuring a school building will last a long time, and that it will have its best chance of lasting through a cyclone or earthquake with minimal damage. One of the best things to do is make sure that the footings are properly connected to the floor, the floor to the walls, the walls to the roof frame, and the roof frame to the roof sheet. If everything is properly connected and maintained, the building should last a long time. Carefully set the work out, and make sure things are where they need to be, and that you only disturb the ground needed for the project. Make sure the bottom of the post holes or the trenches for the footings are not too soft or wet.

When digging the foundations, make sure the excavation is large enough and deep enough. The typical minimum requirements are on the drawings and look like the drawing opposite.

Make sure the foundations are clear of debris and water before placing any concrete for the footings. Support embedded posts or any reinforcement while concrete is being placed. Be careful of the steel bars into the posts.

The concrete is to be prepared with the correct ratios of sand, aggregate, and cement, and enough water to make the mixture workable, but not too wet. For normal structural concrete for footings and floors, a ratio of 1 part cement : 2 parts sand : 4 parts aggregate will usually produce a good concrete. The measurement is by volume, not weight, so you must use the same bucket or measuring box to measure the sand, aggregates and cement. As a guide, a 40kg bag

of cement is just under 30 litres. Only fill the bucket or box to an even level, to ensure consistency in the measures. If the sand or aggregates are sourced from ocean beaches, make sure they are well washed with fresh water to remove any salt before they are used. Salt water in the concrete can result in corrosion to the reinforcement steel, which can cause concrete cancer, and result in a greatly shortened usable life of a house, or failure of a structural system in a natural disaster.

For the same reason, it is very important to use potable water in the concrete mix, and only enough water to make the mix usable. If the mix is too wet, the concrete will not become strong enough. Do not use salt water.

Place the concrete as soon as possible after it has been mixed. On hot and sunny, or windy days, the concrete can lose moisture and dry out very quickly before it starts to set, potentially making the concrete weaker than it needs to be. Do not use concrete that has started to set.

### 4.1 Concrete Floors

Because of the expense, concrete floors are best used on sites that are quite flat, to minimise the amount of fill needed under the floor to support it.

Care is needed when a concrete floor is set up, as you will need to be able to place a lot of concrete quickly, and, once the concrete has set, it is very hard to make changes.

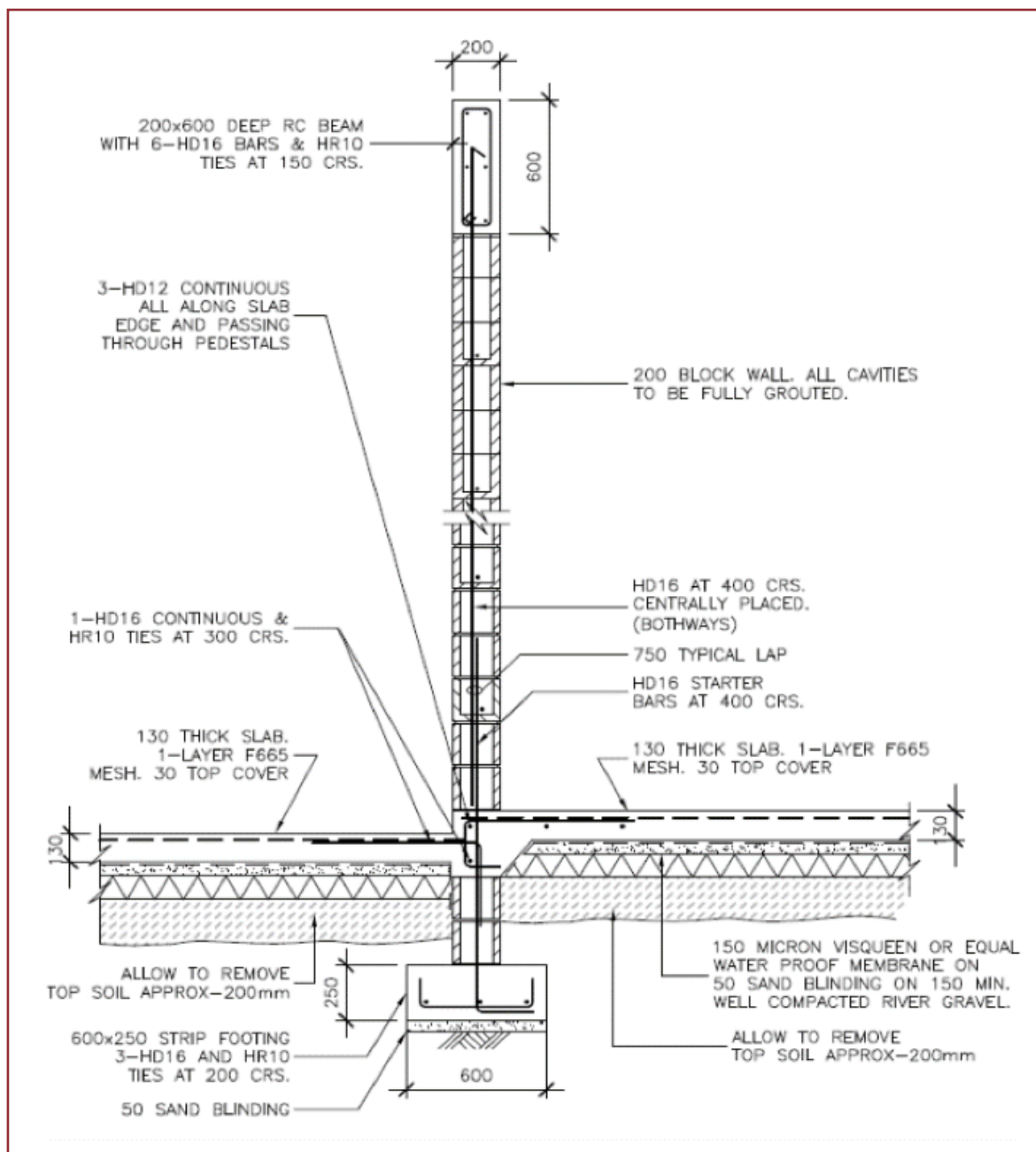

Figure B3: Typical Footing & Wall Detail Section, New Classroom Building, Nailuva District School (Source: Construction Implementation Unit, Ministry of Economy, Fiji)

Initially, remove the top 100mm of top soil from the ground that the concrete floor will cover. Place hardcore fill up to the level that you need and compact it well. It is best to place the fill in layers of up to 150mm at a time and compact it as you go: you can't properly compact a thick layer of fill. You may need to dig part of the fill out for thickenings and different floor levels.

Place a 50mm layer of sand on the top of the fill and compact this layer as well.

Dig out areas of the hardcore where you need to place any drains and set the pipes with the right fall on soft sand. Hold the pipes in place while you relay the fill over the pipes.

Place sheets of Visqueen (builder's black plastic sheeting) on top, to make sure moisture from the ground doesn't come through the concrete. Tape all of the joints of the plastic so that it is fully sealed, and tape the sheet to any penetrations, such as drain pipes.

Set the steel reinforcement mesh in place, at a level so that there is enough concrete covering the steel. This cover is usually at least 25mm.

If the concrete needs to have falls in it, so that you can drain a wet area, be ready to set those levels when the concrete is being placed. Make sure the minimum thickness of concrete and cover to the reinforcement is maintained.

Make sure any reinforcement or bars that extend out of the slab are in place before the concrete sets, unless you plan to drill into the concrete later, and use chemicals to set them.

When the concrete is in place, or while it is being placed, and before it has set too much, the surface can be screeded to the desired levels, and any surface treatments applied, such as trowelling. Different surfaces may receive different treatments, such as footpaths, to make them non-slip, or interior floors that may receive vinyl floor or ceramic tiles.

After the surface has been finalised and set, the

surface should be covered with a wet cloth like hessian, and kept wet for several days, to minimise any surface cracks.

## 4.2 Cyclone connections

As mentioned earlier, all the structural systems in a school building should be properly connected to ensure they can resist the forces from the wind of a cyclone, which can push and pull with great strength in quick succession. It is important that all of the cyclone connections are used, to minimise the risk of a weak link that can fail and cause significant damage to a structure.

# 5. Wall Construction

## 5.1 Concrete masonry walls

Walls can be made from concrete blocks usually when there is a concrete slab for the floor. Because the larger structural masonry blocks used for structural work are hollow in the middle, they need to be backfilled with concrete to ensure they are suitably strong. They also require vertical and horizontal steel reinforcement bars to ensure they are able to resist and transmit loads to the footings. This makes the system quite slow to build, and it can be expensive. However, masonry can be more durable than timber, in part because of the mass of concrete in the system.

The top of a reinforced masonry wall will need to have a bond beam around it, to lock the wall together. The bond beam can use masonry units with the ends open and continuous reinforcement which is concreted together to create a continuous concrete ring beam. Alternatively, a continuous reinforced concrete beam can be formed up and poured.

Concrete masonry should be supplied by a reputable supplier to help ensure that the masonry used is strong enough.

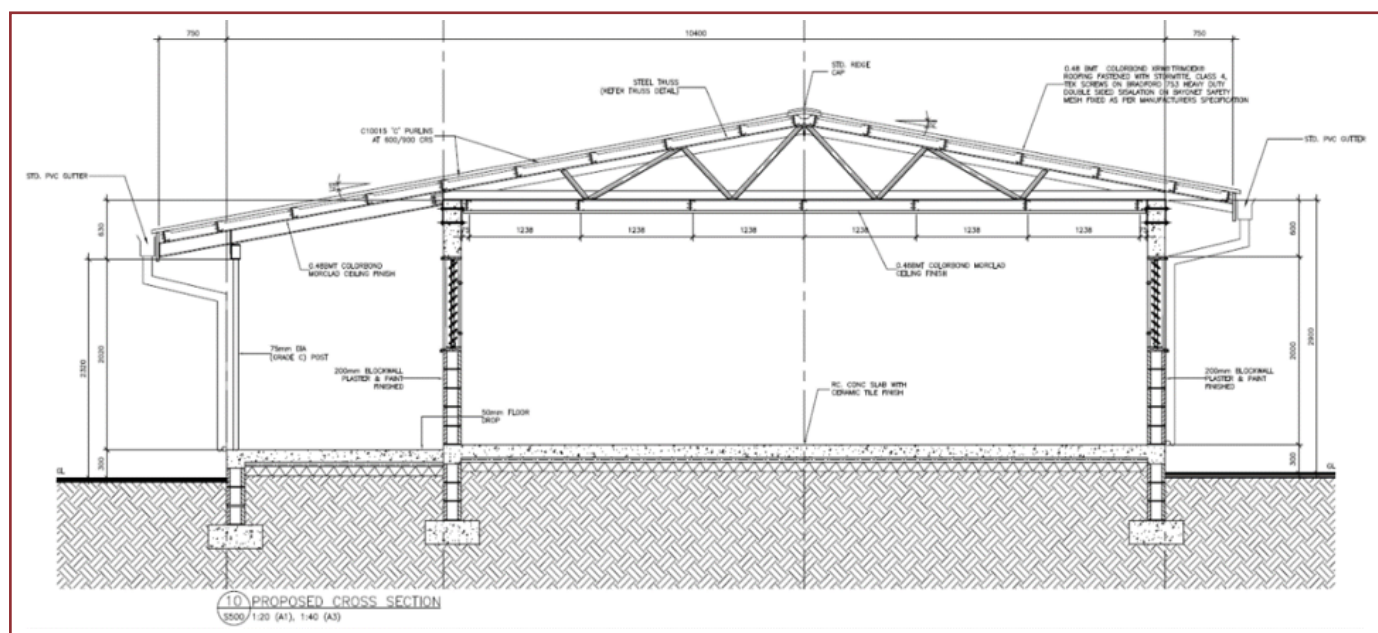

Figure B4: Typical Section, New Classroom Building, Nailuva District School (Source: Construction Implementation Unit, Ministry of Economy, Fiji)

# 6. Roof Framing

There are a number of ways to frame a roof in timber. The sizes of timber required, and their spacing has been worked out to ensure the roof is sufficiently strong. Usually the trusses or roof frames are spaced at 900mm centres, with purlins supporting the roof sheeting at 750mm centres.

The roof framing can extend beyond the wall line, to shade the walls. This has its best effect on the north and south sides of the building. The overhang, or eaves, should not be too far away from the edge of the building, as this can weaken the roof in a cyclone. The roof frame has to connect to the wall frames, and cyclone connections are added to ensure the roof and walls are properly connected to the footings.

Battens or purlins are run on top of the roof framing, and are used to connect the roof sheeting to the roof frame. They require galvanised steel strapping at every connection to ensure the continuity of support.

## 6.1 Bracing

Before any linings are added, the large surfaces of the walls and roof need to be braced to reduce the impact of winds and earthquakes. In concrete masonry walls, the vertical and horizontal reinforcing steel in the walls takes up this role.

In timber framed walls and roofs, the bracing is made using galvanised steel strapping that crosses the planes, connecting opposite corners.

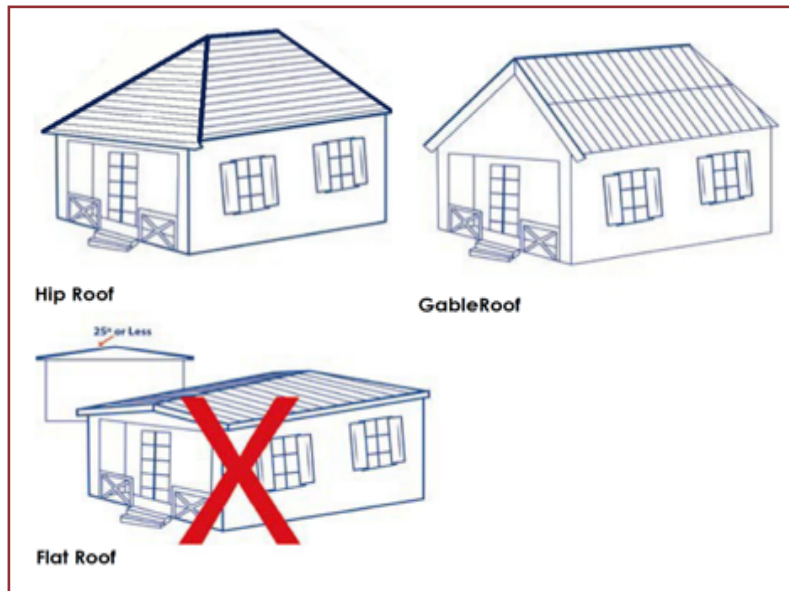

Figure B5: Typical roof shapes (Source: Fiji Rural Housing Unit standard drawings)

## 6.2 Roof Sheeting

The roof sheeting needs to be well connected to the roof framing to ensure it doesn't get lifted off from strong winds. Using roofing screws with cyclone washers to every second crest of the roof sheet will limit the risk of this happening. Additional screws are to be used to every crest at the top connection of the ridge, and at the bottom, at the eaves, as well.

A layer of sisalation should be placed immediately under the roof sheeting, to help reduce the heat gain from the large area of roof.

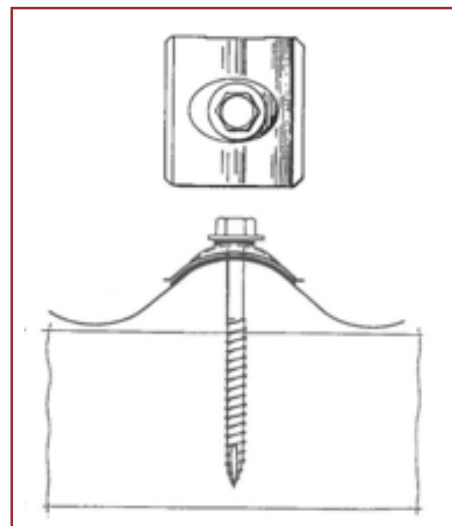

Figure B6: No 14 Type 17 Screw with cyclone washer assembly (Source: Home Building Manual, Fiji)

# 7. Simple Maintenance and Repair Regime

Experience and statistics show that the lack of maintenance is a significant contributing factor in damages to houses and schools by cyclones.

Regular maintenance is necessary to ensure that the structure continues to be cyclone resistant, and can extend the life of a building if carried out regularly. Inspections should be completed at least once a year well before the start of cyclone season (to allow enough time for any work to be organised and completed) and after any significant weather events.

Inspect the entire building regularly, inside and out, to see if anything needs repairing or replacing and fix it immediately if you can, or make a definite plan to fix it if it is an expensive item. A list of each room, and a checklist of things to inspect (ie walls, windows, doors, floors, ceiling, lights....) helps to remember where issues are, and to check for patterns or changes.

The most important areas for regular checks are:

- Site
  - Maintain any open drainage channels around structures, and ensure the ground falls away from buildings toward the drains
  - Remove large trees that could fall on building
  - Look for any trip hazards on paths
- Footings:
  - Insect concrete, and repair or locally replace if concrete is cracked or damaged
  - Remove any termite galleries
- Walls
  - Concrete blocks and slabs for significant cracks: seal cracks if necessary
  - Check paintwork, and plan for repainting very 10 years

- Window & doors
  - Wash down regularly especially if exposed to sea breezes
  - Check window frames, please damaged or broken glass
  - Check exterior doors & frames for damage to corrosion
  - Check door furniture (handles, locks, hinges etc), and make sure fixtures are secure
- Roof
  - Roof cladding for corrosion at panel edges and damage generally
  - Replace missing screws or bolts. Use cyclone washers where necessary.
- Roof structure
  - Check accessible roof structure for soundness.
  - Look into roof space/ceiling for water damage
  - Look in the roof space for missing roof screws (they become very visible as little holes in the roof!)
  - Look for any pest nests, such as birds, rats or wasps
- Joints and connections in timber and masonry construction for structural integrity and durability.

For timber framed buildings, such as teachers houses, including those elevated on wooden or concrete posts:

- check posts for rot, especially those below ground level.
- check concrete capping for damage, and that the capping will shed water away from the post.
- check for termites and arrange for treatment. Obtain specialist advice promptly if termites are found.



# 8. Good Practice in Building Applications & Inspections

## 8.1 Acquiring a Building Permit

of the process of acquiring a building permit that is required for a community school.

This section aims to improve your understanding

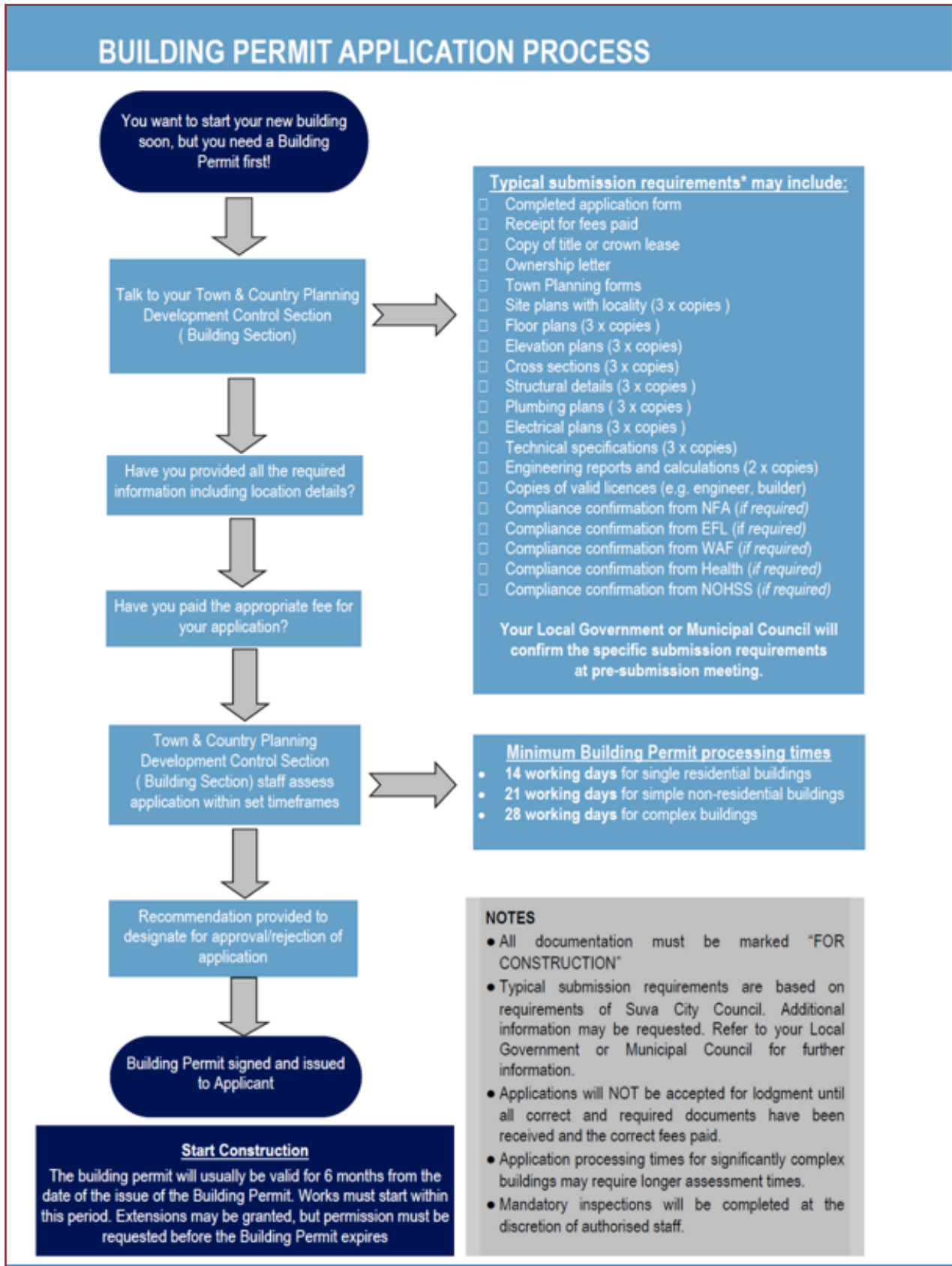

Figure B7: Typical Building Permit process

The flow diagram illustrates the process and the timelines. Obtaining a building permit requires a number of documents and not submitting them can delay the processing of such a permit.

## 8.2 Building Inspections

To ensure that the schools comply with the NBC and the building permit, building inspectors from

the Municipal councils will conduct inspections at multiple stages throughout the construction process. Inspections at critical structural stages of constructions include: 1) foundations; 2) framing; 3) Roof framing & sheeting.

Building inspectors would look for the connections within the different stages and also the integrity on the building as a whole and the compliance with the NBC before issuing a Certificate of Occupancy.

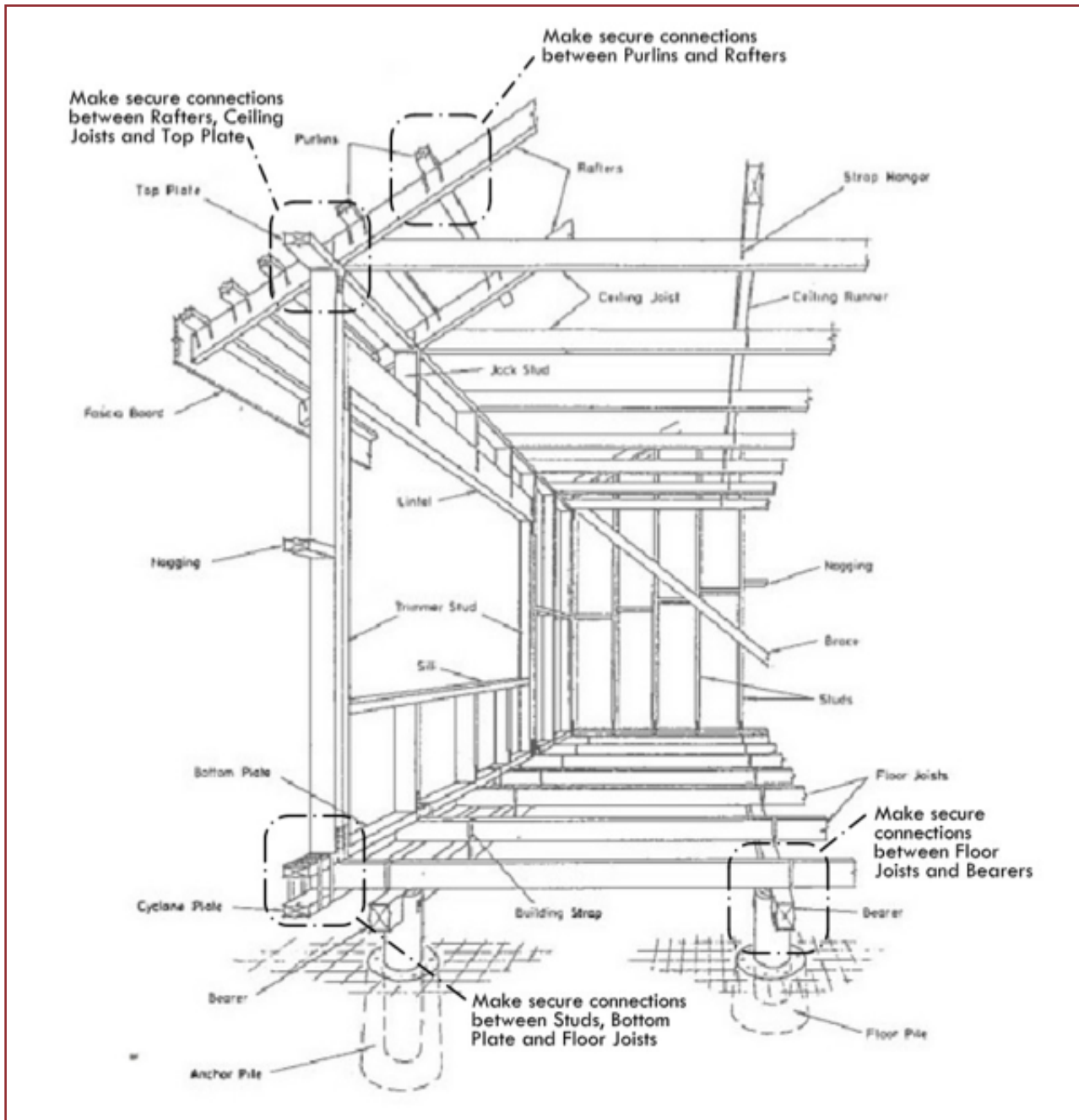

Figure B8: Typical major structural inspections during construction

