

**EXTRAORDINARY  
GOVERNMENT OF FIJI GAZETTE SUPPLEMENT**

No. 7

FRIDAY, 1st FEBRUARY

2013

[LEGAL NOTICE No. 10]

**TRADE STANDARDS AND QUALITY CONTROL DECREE 1992  
(DECREE NO. 24 OF 1992)**

**Trade Standards (Battery Standard) Order 2013**

IN exercise of the powers conferred upon me by section 26 of the Trade Standards and Quality Control Decree 1992 and in considering public interest and recommendation from the Trade Standards Advisory Council, I hereby make this Order—

*Short title and commencement*

1. This Order may be cited as the Trade Standards (Battery Standard) Order 2013 and shall come into force on 1 May 2013.

*Application*

2. This Trade Standard applies to vehicle batteries imported, manufactured and marketed for use in Fiji.

*Definition*

3. In this Order, unless the context otherwise requires—

“Director” means the Director of Trade Standards and Quality Control Office;

“Minister” means the Minister responsible for Industry and Trade; and

“Standard” means the Standard as set out in the Schedule.

*Responsibilities of Importers, Manufacturers and Retailers*

4. A person who imports, manufactures or sells any vehicle battery regulated under this Order must comply with this Order and the Standard.

*Regulator*

5.—(1) The Director of Trade Standards and Quality Control Office shall be the Regulator of the Standard.

(2) The Director or any person authorized in writing by the Director is deemed to be a duly appointed inspector under the Decree for the purposes of this Order and the Standard.

*Sample and Reporting*

6.—(1) The Director or any person authorized in writing by the Director shall take any sample at any time for testing for the purposes of compliance with this Standard.

(2) A manufacturer, importer or retailer of vehicle batteries under this Order, shall submit a Quality test report from the National Association of Testing Authorities (NATA) certified accredited laboratory to—

The Director,  
Trade Standards and Quality Control Office  
Ministry of Industry and Trade  
PO Box 2118  
Government Buildings  
Suva

*Penalties*

7. Any manufacturer, importer or retailer of vehicle batteries who breaches the provisions of this Order shall be subjected to the penalties under the Trade Standards and Quality Control Decree 1992.

*Power to make amendments*

8. The Minister shall have the power to make, amend, suspend or revoke this Order or the guidelines under this Order in relation to labelling and standard.

SCHEDULE

SECTION 1 GENERAL

1.1 SCOPE

This Standard is applicable to lead-acid batteries with a nominal voltage of 12 V, used primarily as a power source for the starting of internal combustion engines, lighting and for auxiliary equipment of internal combustion engine vehicles. These batteries are commonly called 'starter batteries'. Batteries with a nominal voltage of 6 V are also included within the scope of this Standard. All referenced voltages have to be divided by two for 6 V batteries.

This Standard is applicable to batteries for the following purposes:

- (a) Batteries for passenger cars.
- (b) Batteries for commercial and industrial vehicles for normal use.
- (c) Batteries for commercial and industrial vehicles for severe use.
- (d) Batteries for use in deep-cycling applications (e.g. marine use, taxis and coaches).

This Standard is not applicable to—

- (i) batteries for starting railcar internal combustion engines;
- (ii) motorcycle batteries; or
- (iii) aircraft batteries.

NOTE: Further requirements for valve-regulated batteries including; requirements for control valves, integrity of seal (leak test), gas recombination efficiency and endurance towards high temperatures and vibration in the areas of sealing integrity will be considered in the next revision.

## 1.2 REFERENCED DOCUMENTS

The following documents are referred to in this Standard:

AS	
1216	Class labels for dangerous goods
2700	Colour standards for general purposes
IEC	Direct acting indicating analogue electrical measuring instruments
60051	and their accessories
60051-2	Part 2: Special requirements for ammeters and voltmeters
60417	Graphical symbols for use on equipment
61429	Marking of secondary cells and batteries with the international recycling symbol ISO 7000-1135
SAE	
J537	Storage batteries
CEN	
EN 60095-1	Lead-acid starter batteries
60095-1	Part 1: General requirements and methods of test

## 1.3 DEFINITIONS

For the purpose of this Standard, the definitions below apply.

### 1.3.1 Capacity

The capacity of a battery is specified for an electrolyte temperature of  $25 \pm 2^\circ\text{C}$ . It may be shown by the manufacturer either as —

- (a) the rated reserve capacity, in minutes in the case of starter batteries; or
- (b) the 20-hour capacity ( $C_{20}$ ), in ampere hours in the case of deep cycling batteries.

The rated reserve capacity  $C_r$  is the time (in minutes) for which a battery can maintain a discharge of 25 A to a final voltage  $V_f = 10.5$  V.

The 20-hour capacity  $C_n$  is the electric charge (in A.h) that a battery can supply with a current:

$$I_{20} = \frac{C_{20}}{20} \quad \dots 1.1$$

to a final voltage  $V_f = 10.5$  V.

NOTE: The relationship between  $C_{20}$  and  $C_r$  may be estimated by the following equation:

$$C_{20} = -133.3 + \sqrt{(17778 + 208.3 \cdot C_r)} \quad \dots 1.2$$

where

$C_{20}$  = the 20-hour capacity, in ampere hours  
 $C_r$  = the rated reserve capacity, in minutes

This formula is not recommended for  $C_r \geq 480$  min ( $C_{20} \geq 200$  A.h).

NOTE: Equation 1.2 is under review and may require modification to reflect the relationship between  $C_{20}$  and  $C_r$  in the most recent battery designs.

### 1.3.2 Charge acceptance

The current  $I_{ca}$  that a partially discharged battery takes up at 0°C and at constant voltage of 14.4 V.

### 1.3.3 Charge retention

The cold cranking performance of a charged and filled battery after storage on open circuit under defined conditions (temperature, time).

### 1.3.4 Conserved-charged battery

A battery that when supplied contains only a small quantity of electrolyte, mainly absorbed within the plates and separators. The plates are in a charged condition and the battery is activated by the addition of further electrolyte.

### 1.3.5 Dry-charged battery

A new battery may be designated as dry-charged if it can be activated, ready for service, by filling it with the specified electrolyte and in accordance with any specific instructions from the manufacturer.

### 1.3.6 Electrolyte retention

The ability of a battery to retain electrolyte under specified mechanical conditions.

### 1.3.7 Endurance in cycles

The ability of a battery to perform repeated discharge/recharge cycles and long rest periods on open circuit. This ability is tested by a series of cycles and rest periods under specified conditions after which the cold cranking performance is determined.

### 1.3.8 Rated cold cranking amps (CCA)

The discharge current to be shown by the manufacturer that a battery can supply at -18°C for 30 s to a minimum voltage  $U_t = 7.2$  V (i.e. 1.2 V per cell).

### 1.3.9 Valve-regulated cell

A cell which is closed under normal conditions but which has an arrangement which allows the escape of gas if the internal pressure exceeds a predetermined value. Electrolyte is not normally added to a valve-regulated cell.

### 1.3.10 Vented (flooded) cell

Either—

- (a) a secondary cell having a cover provided with an opening through which gaseous products can escape and providing access to the electrolyte through which electrolyte may be added; or

- (b) a secondary cell having a cover provided with a venting system through which gaseous products can escape but with no access to the electrolyte.

NOTE: This opening may be fitted with a venting system.

#### 1.3.11 Vibration resistance

The ability of a battery to maintain service under acceleration forces.

### 1.4 CONDITION ON DELIVERY

New batteries may be supplied in one of the following states:

- (a) In a state ready for use, filled with the appropriate electrolyte to the maximum level. After an initial charge (according to Clause 3.2), the electrolyte density or OCV shall be within the ranges specified in Clause 3.5; or
- (b) In a dry-charged state not filled with electrolyte. The density of the electrolyte to fill such batteries before use shall be in the range 1250 kg/m<sup>3</sup> to 1280 kg/m<sup>3</sup> at 25°C unless otherwise specified by the manufacturer.

## SECTION 2 GENERAL REQUIREMENTS

### 2.1 IDENTIFICATION AND LABELLING

Batteries shall be marked with the following information:

- (a) The name or registered trademark of the manufacturer or supplier, or of both the manufacturer and supplier.
- (b) The address of the manufacturer or supplier whose name, trade-name or trademark is given under (a) above.
- (c) The rated cold cranking amps, in amperes for starter batteries (see Clause 1.3.8).
- (d) The rated reserve capacity, in minutes for starter batteries (see Clause 1.3.1).
- (e) The 20-hour capacity for deep cycling batteries (see Clause 1.3.1)
- (f) The maximum recharging voltage that can safely be applied to the battery.

The information required by Item (b) may be omitted, if the manufacturer or supplier has offices or agents in every State and Territory of Australia and if the omitted information is available from catalogues or similar publications.

All markings and labels shall be legible and durable for the expected service life of the battery.

### 2.2 WARNING LABEL

Batteries shall carry a warning label as shown in Figure 2.1 and a warning label including the following advisory statement or words that clearly convey that meaning, pointing out the explosive hazard associated with the process of charging batteries and the corrosive contents of the battery:

**WARNING: Lead-acid batteries generate explosive gases. Keep sparks, flames, and lighted cigarettes away from battery, when charging or using battery in an enclosed space, provide ventilation. This battery contains sulphuric acid. Avoid contact with skin, eyes or clothing. In event of accident flush with water and call a physician immediately.**

The warning label shall be prominently displayed on the battery in a position that is not likely to be hidden from view when installed in a vehicle. The wording shall be in contrasting colours to the background. The word **WARNING** shall be written in letters having a minimum height of 3 mm. The text of the label shall have letters with a minimum height of 2 mm.



NOTE: For further details see AS 1216.

FIGURE 2.1 WARNING LABEL

### 2.3 MARKING OF POLARITY

Batteries shall carry the marking of polarity, at least of the positive terminal.

#### 2.3.1 Positive terminal

This marking shall take the form of the symbol +, indented or in relief, either on the upper surface of the positive terminal or on the lid adjacent to the positive terminal. The symbol used for marking the positive terminal shall be in accordance with symbol 5005-a: Plus; positive polarity of IEC 60417-2. The value of the dimensions 'a' should be equal to or greater than 5 mm.

#### 2.3.2 Negative terminal

If the negative terminal is also marked, the symbol used shall be in accordance with symbol 5006: Minus; negative polarity of IEC 60417-2. This marking shall also be placed either on the upper surface of the negative terminal or on the lid next to the negative terminal. The size of the negative marking shall correspond to that of the positive marking.

#### 2.3.3 Colours

If, in addition to the above marking, colours are used for the marking of polarity, the colours used shall be as follows:

- (a) Positive terminal—red (refer to AS 2700, Colour 538).
- (b) Negative terminal—black or blue (refer to AS 2700, Colour 104).

NOTE: The marking of polarity by colours is not a requirement of this Standard.

### 2.4 WATER LOSS

Batteries are classified as low water loss if they pass the water consumption test of Appendix I.

NOTE: Low water loss batteries are commonly known as 'maintenance free batteries'.

2.5 RECYCLING SYMBOL

If batteries are to be marked with a recycling symbol, they shall be marked in accordance with IEC 61429.

2.6 TERMINAL POSTS

The preferred type of positive and negative terminal are the two types of tapered terminal posts classified in Table 2.1 and illustrated in Figure 2.4 with the dimensions given in Table 2.2. Provision may be made for the connection of lug type terminals.

Figures 2.2 and 2.3 are the preferred arrangements of terminal location. However, Plan H of Figure 2.3 is the preferred terminal layout for future original equipment batteries.



FIGURE 2.2 TERMINAL LAYOUTS—6 VOLT BATTERIES

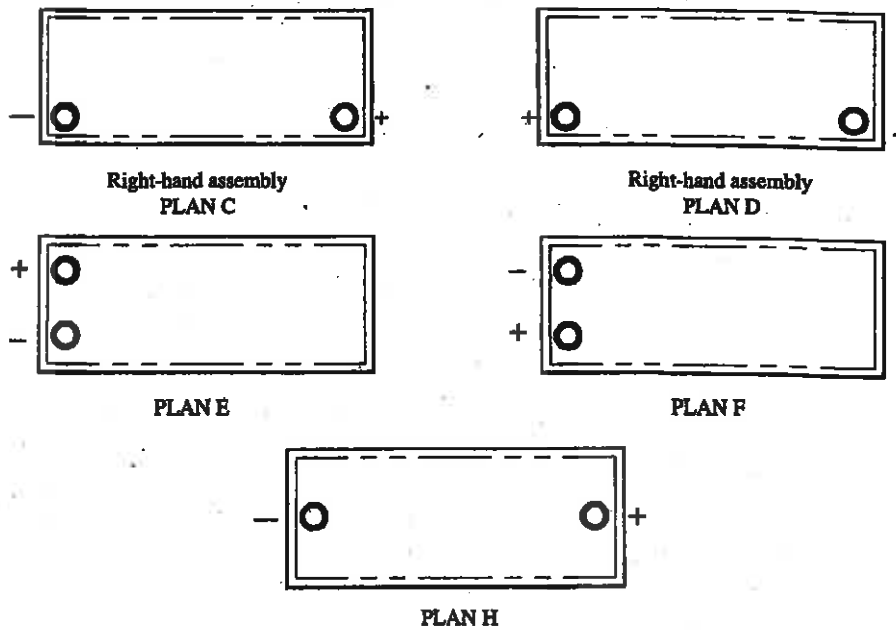

NOTE: Plans C, D and H may also have screw-in type side terminals in addition to the top mounted post terminals shown in the above plans.

FIGURE 2.3 TERMINAL LAYOUTS—12 VOLT BATTERIES

TABLE 2.1  
CLASSIFICATION OF TAPERED TERMINAL POSTS

Classification		Symbol
Tapered terminal	Thin type	T <sub>1</sub>
	Thick type	T <sub>2</sub>

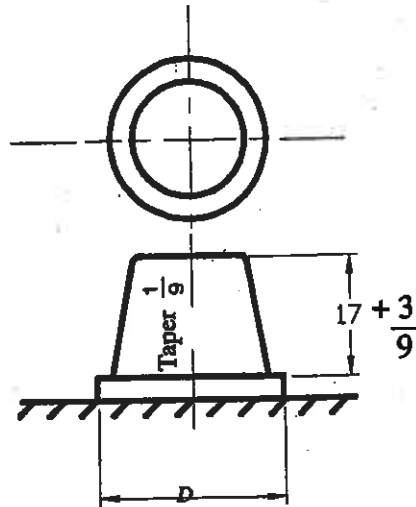

DIMENSIONS IN MILLIMETRES

FIGURE 2.4 DIMENSIONS OF TAPERED TERMINAL POSTS

TABLE 2.2  
DIMENSIONS OF TAPERED TERMINAL POSTS T<sub>1</sub> AND T<sub>2</sub>  
Unit : mm

Classification of tapered terminals	D dimensions	
	Positive terminal	Negative terminal
T <sub>1</sub>	14.7 <sup>0</sup> <sub>-0.3</sub>	13.0 <sup>0</sup> <sub>-0.3</sub>
T <sub>2</sub>	19.5 <sup>0</sup> <sub>-0.3</sub>	17.9 <sup>0</sup> <sub>-0.3</sub>

### SECTION 3 GENERAL TEST CONDITIONS

#### 3.1 SAMPLING OF BATTERIES

All tests shall be carried out on new battery samples. Samples shall be considered as new not later than—



- (a) 60 days after the acid filling and formation date for filled and charged batteries;  
and
- (b) 90 days after the manufacturer's shipment date for dry-charged batteries.

### 3.2 PREPARATION OF BATTERIES BEFORE TEST—DEFINITION OF A FULLY-CHARGED BATTERY

All tests, except the cold cranking amps test of a dry or conserved charge battery, shall commence with fully-charged batteries.

To be considered fully-charged a battery shall:

- (a) For vented batteries  
Be charged at a voltage of  $16\text{ V} \pm 0.1\text{ V}$  for 24 h with the maximum current limited to  $0.15 C_{10}$  (see Clause 1.3.1). The battery temperature shall be maintained in the range  $25^{\circ}\text{C}$  to  $35^{\circ}\text{C}$ . If necessary, an appropriate environmental control system shall be used, e.g. a water bath.
- (b) For valve-regulated batteries  
Be charged at a voltage of  $14.1\text{ V} \pm 0.1\text{ V}$  for 24 h. The battery temperature shall be maintained below  $25^{\circ}\text{C}$ . If necessary, an appropriate environmental control system shall be used, e.g. a water bath.

### 3.3 ACTIVATION OF DRY-CHARGED BATTERIES

Any manufacturer's recommendations concerning activation shall be followed.

### 3.4 MEASURING INSTRUMENTS

#### 3.4.1 Electrical measuring instruments

The accuracy and type of the instruments to be used in the performance of the tests specified in this Standard shall be as follows:

- (a) Voltmeter—Accuracy Class 0.5, resistance not less than  $1000\ \Omega/\text{V}$ , in accordance with IEC 60051-2, or digital voltmeters.
- (b) Ammet—Moving coil, accuracy Class 1, in accordance with IEC 60051-2 or digital ammeters.

#### 3.4.2 Temperature measurement

The thermometers used for measuring temperatures shall have an appropriate range, and the value of each scale division shall not be greater than  $1^{\circ}\text{C}$ . The accuracy of the calibration of the instruments shall be not less than  $0.5^{\circ}\text{C}$ .

#### 3.4.3 Density measurement

The density of the electrolyte shall be measured with a hydrometer with a graduated scale. The value of each division of the scale shall be  $5\text{ kg/m}^3$ . The accuracy of calibration shall be  $5\text{ kg/m}^3$  or better.

#### 3.4.4 Time measurement

The instruments used for measuring time shall be graduated in hours, minutes and seconds. They shall have an accuracy of at least  $\pm 1\%$ .

### 3.5 ELECTROLYTE DENSITY

For the purpose of testing, the density of the electrolyte shall be  $1275 \pm 10 \text{ kg/m}^3$  at  $25^\circ\text{C}$ . However, where the manufacturer's design of a battery makes the use of  $1275 \text{ kg/m}^3$  impractical, the test may be performed at the manufacturer's recommended density if this density is clearly stated in both the test results and is marked on the battery.

## SECTION 4 ASSESSMENT OF COMPLIANCE WITH THIS STANDARD

### 4.1 GENERAL

- (a) All tests shall be carried out in the order stated in Table 4.1.
- (b) Before the commencement of the test methods of Appendices A, B, E to K and Q, batteries shall be restored to their fully charged state in accordance with the manufacturer's instructions. If applicable, the level and density of the electrolyte shall be checked and, if necessary, adjusted.

TABLE 4.1  
SCHEDULE FOR ASSESSMENT OF COMPLIANCE

Characteristic	Test method Appendix	Application	
		Category	
		Batteries not designated low water loss	Low water loss batteries
Leak test*	B	M	M*
Terminal post torque test	C	M	M
Rechargeability and charge rate acceptance test	D	M	M
Cold cranking amps test	E	M	M
Cold cranking amps test of dry or conserved charged battery	F	O	NA
Rated reserve capacity test	G	M	M
20-hour discharge capacity test	H	O	O
Water consumption test	I	O	M
Charge-discharge cycling test	J	M	M
Endurance test	K	M	M
Vibration test	A	M	M
Electrolyte retention test—Tilt	L	M	M†
Electrolyte retention test—Tilt and vibration	M	O	O†
Self-discharge characteristics test	N	M	M
Environment temperature test	O	M	M



7	Charge-discharge cycling test	X	X								
8	Endurance test	X	X								
9	Vibration test			X	X						
10	Electrolyte retention test—Tilt†							X			
11	Self-discharge characteristic test					X	X				
12	Environment temperature test								X		

\* Only applied to batteries with accessible electrolyte.

† Not mandatory for batteries not designated low water loss.

‡ Not applied to valve-regulated batteries that are not used in vehicles, i.e. batteries used for starting stationary engines.

#### 4.4 OPTIONAL TESTS

Batteries may also be subject to the tests listed in Table 4.3. The eleven batteries used for the mandatory tests of Table 4.2 shall be used with an additional battery for test number 4. If one battery fails test number 2, the extra battery (see Clause 4.2) may be substituted for the failed battery.

TABLE 4.3

#### OPTIONAL TESTS THAT MAY BE APPLIED TO THE BATTERIES SELECTED

Test		Battery number										
No	Characteristic	1	2	3	4	5	6	7	8	9	10	11
1	Cold cranking amps test of dry or conserved charged battery	X	X	X	X	X	X	X	X	X	X	
2	20-hour discharge test				X	X	X	X	X	X	X	
3	Electrolyte retention test—Tilt and vibration *							X				
4	Battery flame retardant venting system test											X

\* Not applied to valve-regulated batteries that are not used in vehicles, i.e. batteries used for starting stationary engines.

#### APPENDIX A VIBRATION TEST (Normative)

##### A1 SCOPE

This Appendix sets out a method for determining a battery's ability to withstand vibration under rough road conditions.

**A2 PRINCIPLE**

The battery is subjected to a vibration in a specified manner for a specified period and then tested for its rated reserve capacity.

**A3 APPARATUS**

The following apparatus is required:

- (a) A vibration test machine capable of vibrating the battery at frequencies from 30 Hz to 35 Hz through an acceleration of  $4 \pm 0.5 g_a$  for 4 h.
- (b) Measuring instruments complying with Clause 3.4.

**A4 PROCEDURE**

The procedure shall be as follows:

- (a) Conduct the test in an ambient temperature of  $27 \pm 3^\circ\text{C}$ .
- (b) Condition the battery in accordance with Clause 3.2 and allow a minimum of 4 h for the temperature of the battery to stabilize at the ambient temperature.
- (c) Vibrate the battery for 4 h with the battery in the normal position. The vibrations shall be harmonic motion having a frequency of 30 to 35 Hz through an acceleration of  $4 \pm 0.5 g_a$  peak-to-peak.
- (d) After vibrating the battery, test it for rated reserve capacity in accordance with Appendix G.
- (e) Recharge the battery then disassemble it for internal examination.

**A5 REPORTING OF RESULTS**

The following shall be reported:

- (a) Battery identification.
- (b) Signs of physical deterioration.
- (c) The rated reserve capacity in minutes.
- (d) Reference to this test method.

**A6 ACCEPTANCE CRITERIA**

A battery shall be considered to have passed this test if—

- (a) there is no visible sign of battery damage;
- (b) it meets or exceeds 80% of its rated reserve capacity; and
- (c) internal components shall exhibit no major mechanical failure such as dropped plates or perforation of the separators

**APPENDIX B  
LEAK TEST  
(Normative)**

**B1 SCOPE**

This Appendix sets out a method for testing the sealing of cells and battery containers to the outside atmosphere.

**NOTE:** This test is not applied to batteries that have inaccessible electrolyte.

**B2 PRINCIPLE**

Each cell of the battery is pressure-tested in turn to find any inter-cell leaks or cracks.

**B3 APPARATUS**

The apparatus shall consist of a compressed air supply capable of delivering air at a pressure of at least 20 kPa, fitted with a stop valve, a pressure gauge and a nozzle. The pressure gauge shall be capable of measuring 20 kPa and of differentiating clearly a pressure change of 0.4 kPa. The nozzle shall be capable of making an airtight connection with the filler holes of the battery.

**B4 PROCEDURE**

The procedure shall be as follows:

- (a) Connect the compressed air supply to a cell of the battery by means of the nozzle.
- (b) Open the stop valve and allow the pressure in the cell to reach 20 kPa.
- (c) Close the stop valve.
- (d) Ten seconds after closing the stop valve read the pressure gauge and record the change in pressure.
- (e) Repeat Steps (a) to (d) for each of the other cells.

**B5 REPORTING OF RESULTS**

The following shall be reported:

- (a) Battery identification.
- (b) Pressure loss in any of the cells.
- (c) Reference to this test method.

**B6 ACCEPTANCE CRITERIA**

A battery shall be considered to have passed this test if the air pressure loss in any cell does not exceed 2 kPa.

**APPENDIX C**  
**TERMINAL POST TORQUE TEST**  
(Normative)

**C1 SCOPE**

This Appendix sets out the method for determining the effectiveness of the fixing of terminal posts to a battery container. It determines whether the seal between the terminal post and the case can be impaired by normal fitting of connection leads.

**C2 PRINCIPLE**

The terminals of a battery are subjected to a torque test. The battery is then inspected and given a leak test to determine if any failure has occurred.

**C3 APPARATUS**

The following apparatus is required:

- (a) A torque wrench fitted with an adaptor to the type of terminals under test.
- (b) A compressed air supply in accordance with Paragraph B3 of Appendix B.

**C4 PROCEDURE**

The procedure shall be as follows:

- (a) Fit the torque wrench and adaptor to the terminal post. Apply a torque of 11.8 Nm for a thin type terminal  $T_1$  and 14.7 Nm for a thick type terminal  $T_2$  in a direction perpendicular to the axis of the terminal post and parallel to the top of the battery.

NOTE: Refer to Table 2.1 and Table 2.2 for the classification and dimensions of terminal types  $T_1$  and  $T_2$ .

- (b) Remove the torque wrench and perform the leak test described in Appendix B.
- (c) Inspect the terminal post, the cover and the seal between the post and cover.

**C5 REPORTING OF RESULTS**

The following shall be reported:

- (a) Battery identification.
- (b) Pressure losses in any of the cells.
- (c) Signs of visible damage to the terminal post, the cover or the seal between the post and cover.
- (d) Reference to this test method.

**C6 ACCEPTANCE CRITERIA**

A battery shall be considered to have passed this test if there is no visible damage to the cover or seal and no visible spillage of electrolyte.

**APPENDIX D**  
**RECHARGEABILITY AND CHARGE RATE ACCEPTANCE**  
(Normative)

**D1 SCOPE**

This Appendix sets out a method for determining the charge acceptance of a new and unused wet battery immediately after a controlled discharge.

**D2 PRINCIPLE**

A discharged battery is refrigerated and then charged at a specified voltage for a specified time and the charge current is measured.

**D3 APPARATUS**

The following apparatus is required:

- (a) Measuring instruments complying with Clause 3.4.
- (b) A refrigerator capable of maintaining the battery temperature at  $0 \pm 1^\circ\text{C}$ .

**D4 PROCEDURE**

The procedure shall be as follows:

- (a) Within 2 h to 8 h of conditioning the battery in accordance with Clause 3.2

discharge the battery at 25 A (the reserve capacity rate) to a terminal voltage of 10.5 V.

- (b) Immediately place the battery in a cold chamber set at 0°C and wait until the electrolyte of the centre cell reaches 0°C. Where access to the electrolyte is not possible, the battery is to remain in the cold chamber for a minimum period of 16 h.
- (c) With the battery in a cold chamber, at  $0 \pm 1^\circ\text{C}$  ambient, charge the battery at a constant voltage equivalent to 2.4 V per cell (14.4 V for 12 V battery), and measure the charge current value after 10 min.

#### D5 REPORTING OF RESULTS

The following shall be reported:

- (a) Battery identification.
- (b) The charge current measured at the end of the 10 min charge period.
- (c) Reference to this test method.

#### D6 ACCEPTANCE CRITERIA

A battery shall be considered to have passed this test if the charge current measured at the end of the 10 min charge period is not less than 0.04 times the rated cold cranking amps.

### APPENDIX E RATED COLD CRANKING AMPS TEST (Normative)

#### E1 SCOPE

This Appendix sets out a method for testing a battery's cold cranking amps rating. It determines a battery's ability to maintain a sufficiently high voltage for ignition requirements under severe cold starting conditions while supplying the high engine cranking current for a sufficiently long time to ensure a start.

NOTE: This test is based on the cold cranking test (30 s test) of SAE J537.

#### E2 PRINCIPLE

The battery is first refrigerated and then discharged at rated cold cranking amps for a specified period. The terminal voltage after this time is measured.

#### E3 APPARATUS

The following apparatus is required:

- (a) Measuring instruments complying with Clause 3.4.
- (b) A refrigerator capable of maintaining the battery temperature at  $-18 \pm 1^\circ\text{C}$ .

#### E4 PROCEDURE

The procedure shall be as follows:

- (a) Condition the battery by fully charging it in accordance with Clause 3.2.
- (b) Place the battery in the refrigerator until the temperature of the centre cell reaches  $-18 \pm 1^\circ\text{C}$ .



- (c) Discharge the battery at the rated cold cranking amps for 30 s. Throughout the discharge hold the current constant to within  $\pm 1\%$  of the rated cold cranking amps. At the end of the 30 s discharge period, measure and record the battery terminal voltage under load.
- (d) If, after Step (c), the battery terminal voltage is less than 7.2 V, Steps (a), (b) and (c) may be repeated twice.

#### **E5 REPORTING OF RESULTS**

The following shall be reported:

- (a) Battery identification.
- (b) The discharge current.
- (c) The battery terminal voltage after 30 s on the first discharge, and if applicable on the second and third discharge.
- (d) Reference to this test method.

#### **E6 ACCEPTANCE CRITERIA**

A battery shall be considered to have passed this test if the battery terminal voltage is not less than 7.2V on the first discharge and if applicable on the second or third discharge.

### **APPENDIX F**

#### **RATED COLD CRANKING AMPS TEST OF A DRY OR CONSERVED-CHARGED BATTERY** (Normative)

##### **F1 SCOPE**

This Appendix sets out a method for testing the cold cranking amps rating of a dry or conserved-charged battery. It determines a battery's ability to start a vehicle without an intervening charge, once the electrolyte has been restored to the battery.

##### **F2 PRINCIPLE**

The battery and its electrolyte are conditioned separately and then combined and allowed to stand. The battery is then discharged in a specified manner and the terminal voltage is recorded at specified intervals of time.

##### **F3 APPARATUS**

The following apparatus is required:

- (a) Measuring instruments complying with Clause 3.4.
- (b) A refrigerator capable of maintaining the battery and electrolyte temperature between  $-2.2^{\circ}\text{C}$  and  $0^{\circ}\text{C}$ .

##### **F4 CONDITIONING**

The battery shall be stored for no more than 90 days from the date of manufacture. If stored, the battery shall be kept in a dry place. The battery shall be held at a temperature of  $25 \pm 2^{\circ}\text{C}$  for 24 h before testing.

**F5 PROCEDURE**

The procedure shall be as follows:

- (a) Place the battery and electrolyte in the refrigerator for at least 18 h until both the battery and electrolyte are between  $-2.2^{\circ}\text{C}$  and  $0^{\circ}\text{C}$ .
- (b) Remove the battery and electrolyte from the refrigerator and immediately fill the battery with the electrolyte.
- (c) Allow the battery to stand for 20 min after filling the last cell, then measure and record the density and temperature of the electrolyte.
- (d) At 75% of the manufacturer's stated cold cranking amps rating, measure and record the terminal voltage 15 s after discharge commences.

**F6 REPORTING OF RESULTS**

The following shall be reported:

- (a) Battery identification.
- (b) The discharge current.
- (c) The battery terminal voltage at the 15 s point.
- (d) Reference to this test method.

**F7 ACCEPTANCE CRITERIA**

A battery shall be considered to have passed this test if the battery terminal voltage measured in Step F5 (d) is not less than 7.2 V

**APPENDIX G**  
**RATED RESERVE CAPACITY TEST**  
(Normative)

**G1 SCOPE**

This Appendix sets out a method for testing the rated reserve capacity of a battery. It determines a battery's ability to supply a constant current of 25 A for lighting and ignition in case of failure of the vehicle's charging system.

**NOTE:** The value of 25 A represents the nominal load that could be expected on a rainy night in a passenger car.

**G2 PRINCIPLE**

The battery is discharged at a specified rate until the terminal voltage falls to 10.5 V. The time taken for the terminal voltage to fall to 10.5 V is the rated reserve capacity, in minutes.

**G3 APPARATUS**

Measuring instruments complying with Clause 3.4 are required.

**G4 PROCEDURE**

The procedure shall be as follows:

- (a) Within 2 h to 8 h of conditioning in accordance with Clause 3.2, discharge the battery at a continuous constant current of  $25 \pm 0.25$  A until the voltage across the battery terminals falls to 10.5V.

- (b) During the discharge, maintain the temperature of the electrolyte at  $25 \pm 2^\circ\text{C}$  and record the following at suitable intervals:
  - (i) The battery terminal voltage.
  - (ii) The discharge current.
  - (iii) The temperature of electrolyte.
- (c) Record the time taken for the voltage across the battery terminals to fall to 10.5 V.
- (d) If the time recorded in Step (c) is less than the rated reserve capacity, Steps (a) to (c) may be repeated twice.

#### G5 REPORTING OF RESULTS

The following shall be reported:

- (a) Battery identification.
- (b) The rated reserve capacity ( $C_r$ ), i.e. the time taken for the battery terminal voltage to fall to 10.5 V, in minutes on the first discharge, and if appropriate on the second or third discharge.
- (c) Reference to this test method.

#### G6 ACCEPTANCE CRITERIA

A battery shall be considered to have passed this test if the time taken for the battery terminal voltage to fall to 10.5 V on the first discharge, or if applicable on the second or third discharge, is equal to or greater than the rated reserve capacity stated by the manufacturer.

### APPENDIX H 20-HOUR DISCHARGE CAPACITY TEST (Normative)

#### H1 SCOPE

This Appendix sets out a method for testing a battery's ability to yield its 20-hour discharge capacity.

#### H2 PRINCIPLE

The battery is discharged at its 20-hour rate until its terminal voltage falls to a specified value. Voltage, current and temperature measurements are taken at suitable intervals. The 20-hour discharge capacity is then calculated.

#### H3 APPARATUS

Measuring instruments complying with Clause 3.4 are required.

#### H4 PROCEDURE

The procedure shall be as follows:

- (a) Within 2 h to 8 h of conditioning in accordance with Clause 3.2, discharge the battery at a continuous current of  $(0.05 \times C_{20})$  A until the voltage measured across the battery terminals falls to 10.50 V.

- (b) During the discharge period, maintain the temperature of the electrolyte in the range 18°C to 27°C and record the following at suitable intervals:
- (i) The battery terminal voltage.
  - (ii) The discharge current.
  - (iii) The temperature of electrolyte.
- (c) When the voltage across the battery terminals has fallen to 11.40 V, record the time, and then record the voltage at 30 min intervals. When the voltage falls to 10.80 V, record the time, and then record the voltage at 15 min intervals.
- (d) End the discharge when the voltage across the battery terminals has fallen to 10.50 V.
- (e) Calculate the capacity in ampere hours from the following equation: ... H1
- $$C_0 = 0.05 C_{20} t$$

where

- $C_0$  = capacity at 2°C, in ampere hours  
 $\theta$  = the average value of the initial and final electrolyte temperatures measured in the central cell(s), in degrees Celsius  
 $t$  = the duration of discharge, in hours.

If 2°C differs from the reference temperature of 25°C during discharge, the capacity shall be corrected to its theoretical value at 25°C by the following equation:

$$C_{25} = \frac{C_0}{1 + K(\theta - 25)} \quad \dots \text{H2}$$

where

- $C_{25}$  = capacity corrected to 25°C, in ampere hours  
 $K$  = 0.01, the temperature coefficient of variation of capacity for temperatures between 18°C and 27°C (this represents a capacity variation of 1% per degree Celsius of the temperature difference from 25°C).

- (f) If after Step (e) the battery fails to achieve the 20-hour capacity stated by the manufacturer, Steps (a) to (e) may be repeated twice.

## H5 REPORTING OF RESULTS

The following shall be reported:

- (a) Battery identification.
- (b) The discharge current.
- (c) The duration of discharge.
- (d) The average electrolyte temperature.
- (e) The calculated 20-hour discharge capacity on the first discharge and if applicable on the second or third discharge.
- (f) Reference to this test method.

## H6 ACCEPTANCE CRITERIA

A battery shall be considered to have passed this test if the battery achieves the 20-hour capacity stated by the manufacturer.

**APPENDIX I**  
**WATER CONSUMPTION TEST—LOW WATER LOSS BATTERIES**  
(Normative)

**NOTE:** This test is not applied to valve-regulated batteries.

**I1 SCOPE**

This Appendix sets out a method for measuring the rate of water usage of a battery.

**I2 PRINCIPLE**

A fully charged battery is maintained at a constant temperature and given an overcharge. Its weight loss during the overcharge is measured.

**I3 APPARATUS**

The following apparatus is required:

- (a) Measuring instruments complying with Clause 3.4.
- (b) A water bath or an oven capable of maintaining the battery at  $40\pm 2^\circ\text{C}$ .
- (c) Charging equipment capable of delivering  $14.40\pm 0.05$  V constant voltage.

**I4 PROCEDURE—**

The procedure shall be as follows:

- (a) Condition the battery by fully charging it in accordance with Clause 3.2.
- (b) Clean dry and weigh the battery to an accuracy of  $\pm 0.05\%$ .
- (c) Place the battery in a water bath maintained at a temperature of  $40^\circ\text{C}\pm 2^\circ\text{C}$ . The terminal base of the battery shall be at least 15 mm but no more than 25 mm above the level of the water. If several batteries are in the same water bath, then the distance between them and the distance to the walls of the bath shall be at least 25mm
- (d) Charge the battery at a constant voltage of  $14.40\text{ V}\pm 0.05\text{ V}$  (measured across the battery terminals) for a period of 500 h.
- (e) Immediately after this overcharge period, repeat Step (b) using the same scales.
- (f) Record the loss in weight of the battery.

**I5 REPORTING OF RESULTS**

The following shall be reported:

- (a) Battery identification.
- (b) The weight loss of the battery in  $\text{g}/\text{min } C_r$ .
- (c) Reference to this test method.

**I6 ACCEPTANCE CRITERIA—**

A battery shall be considered to have passed this test if its weight loss is not more than  $4\text{ g}/\text{min } C_r$ .

**APPENDIX J**  
**CHARGE-DISCHARGE CYCLING TEST**  
(Normative)

**J1 SCOPE**

This Appendix sets out a method for determining the number of charge-discharge cycles of a 12 V battery or two 6 V batteries connected in series. It shall be applied only if the battery has had its cold cranking amps determined in accordance with Appendix E or Appendix F.

This test simulates automotive service where a battery operates in a voltage regulated charging system. It subjects a battery to charge and discharge cycles resulting in failure modes comparable to those encountered in automotive service. It does not establish the whole calendar life of the battery in a vehicle that may be affected by several parameters.

**J2 PRINCIPLE**

A battery is maintained at a constant temperature and is charged and discharged for a specified time until the terminal voltage during a discharge reaches a specified value.

**J3 APPARATUS**

The following apparatus is required:

- (a) Measuring instruments complying with Clause 3.4.
- (b) A water bath capable of maintaining the battery at  $40 \pm 3^\circ\text{C}$ .

**J4 PROCEDURE**

The procedure shall be as follows:

- (a) Condition the battery to 100% state of charge in accordance with Clause 3.2.
- (b) Immerse the battery in a water bath maintained at a temperature of  $40 \pm 3^\circ\text{C}$ . Ensure that the top of the battery case does not emerge more than 25 mm above the level of the water. Support the battery so that it is insulated from the bottom of the water bath.
- (c) Discharge the battery for  $4 \text{ min} \pm 1 \text{ s}$  at  $25 \pm 0.05 \text{ A}$ , then charge at a maximum voltage of  $14.8 \pm 0.03 \text{ V}$  and maximum current rate of  $25 \pm 0.05 \text{ A}$  for  $10 \text{ min} \pm 3 \text{ s}$ .
- (d) Repeat Step (c) for 100 h and ensure that the switching delay from termination of charge to start of discharge and from termination of discharge to start of charge is not greater than 10 s.
- (e) Allow the battery to stand on open circuit for 48 h in the water bath at  $40 \pm 3^\circ\text{C}$ .
- (f) With the battery still in the water bath, discharge the battery at a rate equal to the rated cold cranking amps test (see Appendix E or Appendix F). If the battery fails to maintain 7.2 V for 30 s then the test is completed. If, however, the battery maintains 7.2 V for 30 s then proceed to Step (g).

- (g) Repeat Steps (c) to (f) but commence Step (c) with the charge portion of the cycle. The test is completed when the battery fails to maintain 7.2 V for 30 s on the rated cold cranking amps test in Step (f).

NOTE: If applicable, water should be added as required during the cycling portion of the test.

#### **J5 REPORTING OF RESULTS**

The following shall be reported:

- (a) Battery identification.
- (b) The number of charge-discharge cycles to the point where the battery fails to maintain 7.2V for 30 s.
- (c) Reference to this test method.

#### **J6 ACCEPTANCE CRITERIA**

A battery shall be considered to have passed this test if the number of charge-discharge cycles determined is not less than that specified by the manufacturer.

### **APPENDIX K ENDURANCE TEST (Normative)**

#### **K1 SCOPE**

This Appendix sets out a method for determining the number of charge-recharge cycles of a battery. It shall be applied only if the battery has had its cold cranking amps determined in accordance with Appendix E or Appendix F.

This test applies to 12 V storage batteries that operate in a voltage regulated charging system. It simulates heavy-duty applications by subjecting the battery to deeper discharge and charge cycles than those encountered in starting a vehicle.

The deeper discharge and charge cycles in service may be due to the following conditions:

- (a) Frequent occurrences of total electrical load exceeding the alternator output.
- (b) Frequent occurrences of the battery system supplying the electrical load with the ignition switch off.
- (c) Frequent occurrences of prolonged vehicle storage combined with high off-key loads.

#### **K2 PRINCIPLE**

Batteries shall be tested either in accordance with Procedure 1 (Paragraph K4) or in accordance with Procedure 2 (Paragraph K5) as applicable according to intended battery use.

Procedure 1 is appropriate for batteries for use in passenger vehicles, light commercial vehicles and similar applications.

Procedure 2 is appropriate for batteries used in trucks, buses, taxis, agricultural vehicles, machinery used for public works and similar applications and for deep cycle applications.

A battery is maintained at a constant temperature and is charged and discharged for a specified time until the terminal voltage during a discharge reaches a specified value.

### K3 APPARATUS

The following apparatus is required:

- (a) Measuring instruments complying with Clause 3.4.
- (b) A water bath capable of maintaining the battery at  $40^{\circ} \pm 2^{\circ} \text{C}$ .

### K4 PROCEDURE 1

The procedure shall be as follows:

- (a) Condition the battery to 100% state of charge in accordance with Clause 3.2.
- (b) Throughout the whole test period, with the exception of the rapid discharge test at the temperature  $-18^{\circ} \text{C}$  (see Step (e)) place the battery in a water-bath at a temperature of  $(40 \pm 2)^{\circ} \text{C}$ . Ensure that the top of the battery case does not emerge more than 25 mm above the level of the water. Support the battery so that it is insulated from the bottom of the water bath. A minimum space of 25 mm shall be maintained around each battery. Add water as necessary during the test to maintain electrolyte levels in accordance with the manufacturer's recommendations except for low water loss batteries.
- (c) Connect the battery to a device where it undergoes a continuous series of cycles, each cycle comprising—
  - (i) a discharge for 1 h at the following current in amperes
 
$$I = 0.15 C_r$$
  - (ii) immediately followed by a recharge for 2 h at a constant voltage of  $(14.80 \pm 0.05) \text{V}$ , the maximum current in amperes being limited to
 
$$I_{\text{max}} = 0.3 C_r$$
- (d) After a series of 32 cycles of discharge and recharge, in accordance with Step (c), disconnect the battery from the endurance circuit and allow it to remain on open circuit for a period of 72 h. Recharge the battery according to Item (ii) of Step (c).
- (e) The whole sequence of 32 cycles, followed by the open-circuit period, constitutes one *endurance test unit*. After three such units submit the battery to another series of 32 cycles and an open-circuit period of 72 h. Without recharge, remove the battery from the water-bath, cool it for a minimum of 20 h to an electrolyte temperature of  $(-18 \pm 1)^{\circ} \text{C}$  (measured in a central cell) and discharge it at the current  $0.6 I_{\text{sc}}$ .
- (f) After 30 s of discharge measure the voltage across the battery terminals and then terminate the discharge

### K5 PROCEDURE 2

The procedure shall be as follows:

- (a) Condition the battery to 100% state of charge in accordance with Clause 3.2.
- (b) Throughout the whole test period, with the exception of the rapid discharge test at the temperature  $-18^{\circ} \text{C}$ , place the battery in a water bath maintained



at a temperature of  $40 \pm 2^\circ\text{C}$ . Ensure that the top of the battery case does not emerge more than 25 mm above the level of the water. Support the battery so that it is insulated from the bottom of the water bath. A minimum space of 25 mm shall be maintained around each battery. Add water as necessary during the test to maintain electrolyte levels in accordance with the manufacturer's recommendations except for low water loss batteries.

- (c) Connect the battery to a device where it undergoes a continuous series of cycles, each cycle comprising—
- (i) a charge for 5 h at a constant voltage of  $(14.80 \pm 0.05)$  V, the maximum current in amperes being limited to
  - (ii)  $I_{\text{max}} = 0.15 C_r$
  - (iii) immediately followed by a discharge for 2 h with a current of  $0.15 C_r$ .
- (d) At the end of the discharge of cycle 14, the discharge voltage shall be not less than 10.0 V. After recharging in accordance with Step (c), disconnect the battery from the endurance test circuit and allow it to remain on open circuit for a period of 70 h.
- (e) The whole sequence of 14 cycles followed by the open circuit period constitutes one endurance test unit. Immediately after five endurance test units have been completed and without recharge, remove the battery from the water bath, cool it to an electrolyte temperature of  $(18 \pm 1)^\circ\text{C}$  (measured in a central cell) for at least 20 h and then discharge it with a current of  $0.6 I_{\text{cc}}$ .
- (f) After  $(30 \pm 1)$  s of discharge, measure the voltage across the battery terminals and then terminate the discharge.

#### K6 REPORTING OF RESULTS

The following shall be reported:

- (a) Battery identification.
- (b) The battery terminal voltage in Step (f) of either Procedure 1 or Procedure 2.
- (c) Reference to this test method.

#### K7 ACCEPTANCE CRITERIA

A battery shall be considered to have passed this test if the battery terminal voltage measured in Step (f) of either Procedure 1 or Procedure 2 is 7.2 V or greater.

### APPENDIX L ELECTROLYTE RETENTION TEST—TILT (Normative)

#### L1 SCOPE

This Appendix sets out the method for testing the ability of a battery to withstand lateral accelerations and decelerations without ejection of the electrolyte. It determines the ability of a battery to withstand the forces that may be applied to it during operation in a vehicle. The angle of tilt and the rate of its application simulate those forces.

**L2 PRINCIPLE**

A battery is tilted and the behaviour of the electrolyte is observed.

**L3 APPARATUS**

A ramp having a slope of 45° is required.

**L4 PROCEDURE**

The procedure shall be as follows:

- (a) Allow the battery to stand on open circuit for not less than 4 h.
- (b) Adjust the electrolyte levels of all cells to the maximum height specified by the manufacturer.
- (c) Charge the battery at a current equal to 0.015 times the rated cold cranking amps for 30 min. Clean all external surfaces to remove electrolyte, and refit the vent plugs or stoppers
- (d) Within 15 min of the termination of the charge given in Step (c), tilt the battery in the forward, backward and both side directions at intervals of not less than 30 s between tilts as follows:
  - (i) Tilt 45° from the vertical within a maximum period 1 s.
  - (ii) Hold at 45° from the vertical for a period of 3 s.
  - (iii) Return to the vertical position for a maximum period of 1 s.
  - (iv) Hold in the vertical position for a minimum of 30 s.
- (e) Visually inspect the battery for any sign of electrolyte spillage.

**L5 REPORTING OF RESULTS**

The following shall be reported:

- (a) Battery identification.
- (b) Spillage of electrolyte and the tilt direction in which the spillage occurred.
- (c) Reference to this test method.

**L6 ACCEPTANCE CRITERIA**

A battery shall be considered to have passed this test if there is no visible spillage of electrolyte.

**APPENDIX M****ELECTROLYTE RETENTION TEST – TILT AND VIBRATION**

(Normative)

**M1 SCOPE**

This Appendix sets out a method for determining a battery's ability to retain electrolyte under tilt and motion conditions. It determines a battery's ability to withstand the forces that may be applied to it during transportation and its ability to operate in off-road conditions. The vibration and angles of tilt simulate the forces concerned.

**M2 PRINCIPLE**

The battery is simultaneously tilted and vibrated and the behaviour of the electrolyte is observed.

**M3 APPARATUS**

A vibration test machine capable of vibrating the battery at a frequency between 30 Hz and 35 Hz through an acceleration of  $4 \pm 0.5 g_n$  peak-to-peak is required.

**M4 PROCEDURE**

The procedure shall be as follows:

- (a) Mount a fully charged battery, topped up to its recommended electrolyte level, in the vibration machine so that the battery is tilted  $30^\circ$  about its longest axis. If the vents are not on the centre line of the battery cover, the battery shall be tilted so that the vents are on the low side of the centre line.
- (b) Vibrate the battery at frequencies from 32 Hz to 35 Hz through an acceleration of  $4 \pm 0.5 g_n$  peak-to-peak for 15 min.
- (c) Visually inspect the battery for any signs of spillage of electrolyte.

**M5 REPORTING OF RESULTS**

The following shall be reported:

- (a) Battery identification.
- (b) Spillage of electrolyte.
- (c) Reference to this test method.

**M6 ACCEPTANCE CRITERIA**

A battery shall be considered to have passed this test if there is no visible spillage of electrolyte.

**APPENDIX N**  
**SELF-DISCHARGE CHARACTERISTICS TEST**  
(Normative)

**N1 SCOPE**

This Appendix sets out a method for testing self-discharge characteristics of a battery. It determines the ability of a battery to withstand long periods of inactivity.

**N2 PRINCIPLE**

A battery is fully charged then left standing on open circuit at a specified temperature for 21 days before being given a rapid discharge.

**N3 APPARATUS**

The following apparatus is required:

- (a) Measuring instruments complying with Clause 3.4.
- (b) A water bath capable of maintaining the battery at  $40 \pm 3^\circ\text{C}$ .

**N4 PROCEDURE**

The procedure shall be as follows:

- (a) Condition the battery to 100% state of charge in accordance with Clause 3.2.
- (b) Place the battery in the water bath with the water temperature at  $40 \pm 3^\circ\text{C}$  for 21 days. The top surface of the battery shall be kept clean and dry during this time.
- (c) Discharge the battery at the rated cold cranking amps  $\pm 1\%$ . After 15 s of discharge, measure and record the battery terminal voltage.

**N5 REPORTING OF RESULTS**

The following shall be reported:

- (a) Battery identification.
- (b) The battery terminal voltage after 15 s of discharge.
- (c) Reference to this test method.

**N6 ACCEPTANCE CRITERIA**

A battery shall be considered to have passed this test if the voltage after 15 s of discharge is not less than 7.2 V.

**APPENDIX O**  
**ENVIRONMENT TEMPERATURE TEST**  
(Normative)

**O1 SCOPE**

This Appendix sets out a method for testing a battery's resistance to large temperature changes. It simulates the temperatures that can occur in the engine compartment of a vehicle.

**O2 PRINCIPLE**

The battery is subject to large temperature changes and then tested for electrolyte leaks.

**O3 APPARATUS**

The following apparatus is required:

- (a) A compressed air supply as described in Paragraph B3 of Appendix B.
- (b) An oven capable of heating the battery to, and maintaining it at,  $90 \pm 2.5^\circ\text{C}$ .
- (c) A refrigerator capable of cooling the battery to, and maintaining it at,  $-18^\circ\text{C}$ .

**O4 PROCEDURE**

The procedure shall be as follows:

- (a) Perform the leak test in accordance with Appendix B at an ambient temperature of  $23 \pm 5^\circ\text{C}$ .
- (b) Store the battery in the oven for 1 h at  $90 \pm 2.5^\circ\text{C}$ .

- (c) Remove the battery from the oven and store it in the refrigerator for 24 h at  $-18^{\circ}\text{C} \pm 3.0^{\circ}\text{C}$ .
- (d) Remove the battery from the refrigerator and store it in the oven for 24 h at  $70 \pm 2.5^{\circ}\text{C}$ .
- (e) Remove the battery from the oven and allow it to cool to  $23 \pm 5^{\circ}\text{C}$  and repeat Step (a).

#### O5 REPORTING OF RESULTS

The following shall be reported:

- (a) Battery identification.
- (b) Any pressure losses in any of the cells.
- (c) Reference to this method.

#### O6 ACCEPTANCE CRITERIA

A battery shall be considered to have passed this test if—

- (a) there is no sign of deformation;
- (b) there are no cracks or leaks where the terminals pass through the container or cell cover and
- (c) the venting system remains functional.

### APPENDIX P BATTERY FLAME RETARDANT VENTING SYSTEM TEST (Normative)

#### P1 SCOPE

This Appendix sets out a method for testing the ability of a battery's venting system to retard effectively the propagation of an externally ignited flame of battery gas into the interior of the battery. Explosive mixtures of gas are usually present in the interior of a battery.

#### P2 PRINCIPLE

A spark is created in the gases emitted by a battery. The battery is observed to see whether gas ignition occurs within the battery.

#### P3 APPARATUS

**P3.1** If the test is to be conducted on a battery  
The following apparatus shall be provided:

- (a) An explosion chamber with an explosion-proof fan of adequate size to produce approximately one chamber volume change per minute, vented directly to the exterior of the building. (See Figure P1).
- (b) A battery charging source capable of constant voltage or constant current control, with at least 40 A output at 17.5 V.
- (c) A fully charged 12 V battery to serve as an ignition source. This battery shall be equipped with a functional flame retardant venting system.
- (d) The battery on which the test is to be performed.
- (e) Wiring and fittings equivalent to those shown in Figures P2 and P3.

P3.2 If the test is to be conducted on a test fixture  
The following apparatus shall be provided:

- (a) An explosion chamber with an explosion-proof exhaust fan of adequate size to produce a minimum of one chamber volume change per minute, vented directly to the exterior of the building. (See Figure P1).
- (b) A battery charging source capable of constant voltage or constant current control, with at least 40 A output at 17.5 V.
- (c) A fully charged 12 V battery to serve as an ignition source. This battery shall be equipped with a functional flame retardant venting system.
- (d) A second fully charged battery to serve as a gas mixture source. This battery shall be vented only through the test fixture or functional flame retardant venting system.
- (e) A test fixture. (See Figure P4).
- (f) Tubing and fittings equivalent to those shown in Figure P5.

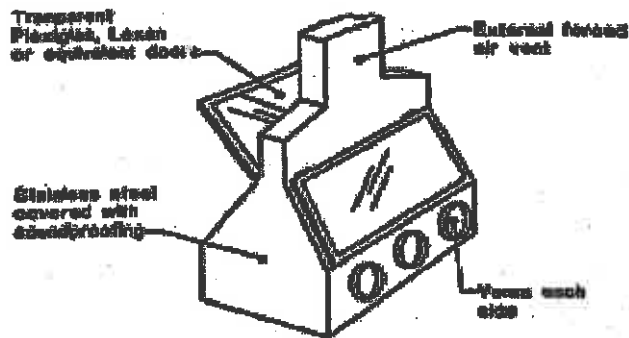

FIGURE P1 TEST CHAMBER

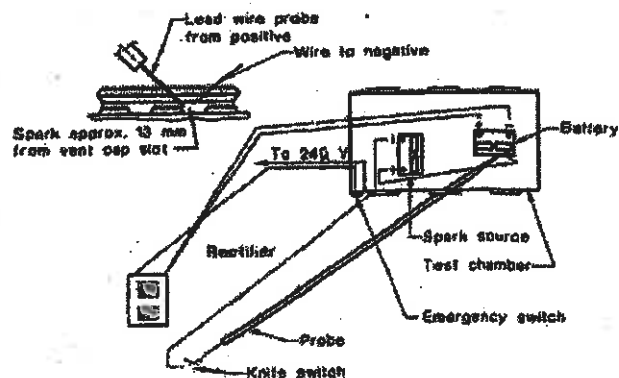

FIGURE P2 SCHEMATIC FOR TEST ON BATTERY

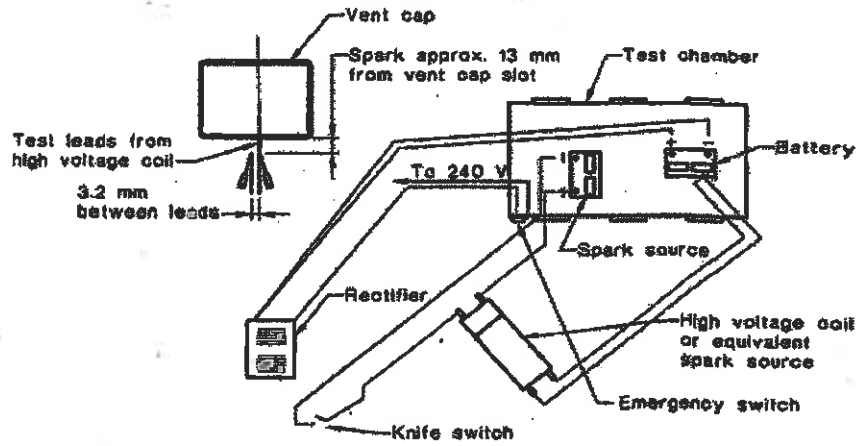

FIGURE P 3 SCHEMATIC FOR TEST ON BATTERY

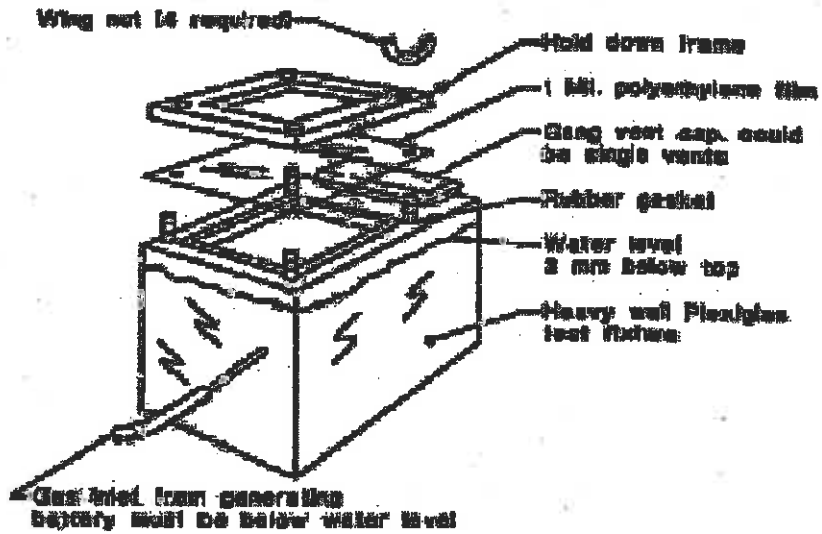

FIGURE P 4 TEST FIXTURE

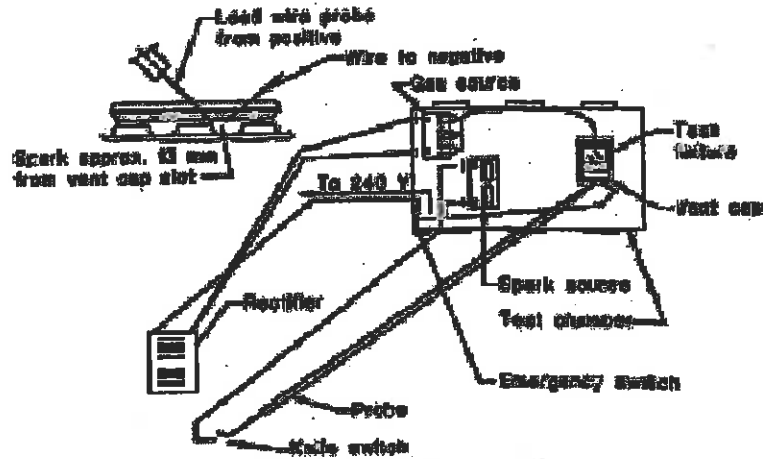

FIGURE P6 SCHEMATIC FOR TEST FIXTURE

#### P4 SAFETY PRECAUTIONS

**Warning:** Testing of a battery venting system can result in an explosion. Extreme caution must be exercised to avoid personal injury. Absolutely no testing shall be permitted where the prescribed safety precautions and procedures are not followed or exceeded.

The following safety precautions shall be taken:

- (a) All test apparatus, except the charging source, shall be fully contained in an externally vented explosion test chamber. (See Figure P1).
- (b) The charging source shall be conveniently placed outside the explosion test chamber for control by testing personnel. The charging circuit shall have two emergency disconnect switches placed—
  - (i) one near the charging source and conveniently placed for control by testing personnel; and
  - (ii) the other at a remote position at least 3 m from the explosion test chamber.

These disconnect switches are intended for emergency use only, since their use may damage some types of chargers.

- (c) A suitable test area shall be designated, e.g. 3 m<sup>2</sup> or more. Signs restricting unauthorized persons from this area shall be posted and observed while any electrical circuit in the explosion test chamber is or could be energized.
- (d) During testing, entry to the test area shall be clearly marked to restrict all persons not fully familiar with all safety requirements and not wearing full protection from the hazards to be encountered.
- (e) Smoking, open flames, unprotected lights or other spark sources shall not be permitted in the area during testing.
- (f) Full face protection devices shall be worn by all persons within the restricted area.



- (g) The battery spark source circuit shall have an emergency disconnect switch conveniently placed for control by testing personnel.
- (h) The exhaust fan of the explosion test chamber shall be operating during the entire spark test procedure. On completion of any test sequence, charging and sparking circuits into the explosion test chamber shall have been interrupted for at least 15 min with the exhaust fan operating before anyone is permitted access to the chamber. This time allows any hydrogen to be purged from the chamber to preclude the possibility of a delayed explosion occurring due to a sustained 'hidden' flame.

**Warning: Hydrogen gas can burn without visible flame.**

## **P5 PROCEDURE**

### **P5. Arrangement of equipment**

#### **P5.1.1 Arrangement of equipment if the test is to be conducted on a battery**

The equipment shall be arranged as follows:

- (a) Arrange the test apparatus as shown in Figure P2 or alternatively as shown in Figure P3.
- (b) Check the test battery system, other than the vent openings, for gas leakage, e.g. with a soap solution.
- (c) Fully charge the spark source battery.
- (d) Fully charge the battery to which the test vent is attached. The battery shall be gassing vigorously.

#### **P5.1.2 Arrangement of equipment if the test is to be conducted on a test fixture**

The equipment shall be arranged as follows:

- (a) Arrange the test apparatus as shown in Figure P5. Place the gas inlet to the test fixture well below the water level as shown in Figure P4 to prevent ignited gases from entering the gas generating battery
- (b) Fill the test fixture with water to 3 mm below the underside of the top. Place the hold down frame over a one mil thickness of polyethylene film cut as shown in Figure P4. Place the frame, with film in place, over the four studs so that the film covers the open area between the fixture and the frame. Finger tighten the wing nuts to ensure a gas-tight seal around the gasket. Fit the vent system to be tested into the fixture.
- (c) Check the test battery system, other than the vent openings, for gas leakage, e.g. with a soap solution.
- (d) Fully charge the spark source battery.
- (e) Fully charge the battery to which the test vent is attached. The battery shall be gassing vigorously.

### **P5.2 Preconditioning**

#### **P5.2.1 General**

The venting system under test shall be preconditioned in accordance with Paragraph P5.2.2 or with Paragraph P5.2.3.

**P5.2.2 Standard preconditioning**

Subject the battery to which the venting system is attached to an overcharge of 2 to 4 A for 16 to 24 h. This will put the vent system in an acid moistened state as is typical of its in-service condition.

**P5.2.3 Hot and cold cycle preconditioning (optional)**

- (a) Place the vent system in a cold box at  $-28.9^{\circ}\text{C}$  for 16 h.
- (b) Remove from cold box and place it in an oven at  $71.1^{\circ}\text{C}$  for 8 h.
- (c) Repeat this sequence for three full cycles.
- (d) At the completion of the third full cycle, condition the vent system as in Paragraph P5.2.2.

**P5.3 Test procedure**

The test procedure shall be as follows. The test shall be conducted within 1 h of completion of preconditioning in accordance with Paragraph P5.2 above.

- (a) Conduct the test at an ambient temperature of  $25^{\circ} \pm 5^{\circ}\text{C}$ .
- (b) The battery temperature should be  $27^{\circ}\text{C}$ . If the battery temperature is above  $27^{\circ}\text{C}$ , a voltage correction of  $-0.038 \text{ V}/^{\circ}\text{C}$  for every degree above  $27^{\circ}\text{C}$  shall be used to guarantee an equivalent amount of gas generation.
- (c) When the test battery is gassing vigorously, charge the battery at a voltage of 2.92 V per cell. (Charging current shall not exceed 40 A).
- (d) Allow the gas flow rate to stabilize. (Gas flow should stabilize in one to five min).
- (e) Create a spark of not less than 0.02 mJ of energy 13 mm from the test vent opening in the path of the gas flow.
- (f) Repeat the spark at 10 s intervals for a minimum of six sparks per vent ensuring that evolved gases are ignited. If the ignited evolved gases ignite the battery, time must be allowed for the battery to self-extinguish or to ignite the gas within the battery.

NOTE: When all gas generated in the 12 V battery is passed into the (simulated 3 cell) test fixture, the effective gassing rate is twice that indicated by the charger current reading, for either single or gang vents.

**P6 REPORTING OF RESULTS**

The following shall be reported:

- (a) Battery identification.
- (b) The preconditioning method (See Paragraph P5.2).
- (c) Whether ignition occurs within the battery or the test fixture.

**P7 ACCEPTANCE CRITERIA**

A battery shall be considered to have passed this test if ignition does not occur within the battery or the test fixture.

Made this 31st day of January 2013.

**A. SAYED-KHAIYUM**  
Attorney-General and  
Minister for Industry and Trade

